

# Service Sheets for the

# Norton

## Commando

## Indexed & Key-Word Searchable

This file has been “captured” for key-word search capability. In doing this, some areas of text have lost their original formatting and appearance, so the sheets may in some small part have lost their “original” appearance.

There is another version of this file, in the same folder as this file you are now reading, which has NOT been “captured” and is NOT key-word searchable, but is exactly as it was printed by Norton. Use whichever version you wish to use.

Note: To use the key word search facility, open this document with Acrobat Reader and click on the “binoculars” symbol on the Tool Bar. You will see a standard-type “find” dialogue box open up, and can use it to search for words or number strings within the document. Have fun!

Reproduced from original Norton material  
with permission of the Norton copyright holders  
by

Heidelberg Desktop Publishing  
1 Simon Court, Heidelberg 3084, Australia

Fax: +61 3 9459 3337, e-mail:<[witepapr@techinfo.com.au](mailto:witepapr@techinfo.com.au)>

© HDT 1999, unauthorised copying prohibited



## SERVICE RELEASE

### I N D E X

NO.	<u>NATURE OF RELEASE</u>
1	Not Issued
2	Carb <b>main</b> jets & Engine No.
3	Carb jets with mod. silencers
4	Gearbox top bolt
5	Clutch slip
6	Incorrect assembly of front forks to frame
7	Exhaust note-silencer and <b>carb.</b>
8	Roadster exhaust part numbers
9	Putting Batteries in service
10	Use of camshaft oil seal guide
11	Method of shimming ISOLASTIC
12	Stiff clutch action cable (i)
13	Excessive oil consumption
14	Removing cylinder head in frame
15	Routine check (on oil pump nut)
16	Adjustment procedure for stop lamp switch
17	Horn adjustment
18	Stiff clutch action (ii) (pivot arm)
19	Operation of steering lock
20	Timing cover gaskets
21	Distribution of service releases
22	Incorrect routing of rocker pipe
23	Spares notes
24	Reconditioning oil pumps
25	Identifying marks on assemblies
26	Clutch Slip-(oil level <b>etc</b> )
27	Shortages in packing
28	Timing chain tension
29	Not Issued
30	Timing marks on rotor
31	Running in oil and oil changes
32	Lubricating rear brake pedal bearing
33	Restricted
34	Water in front brakes
34	1971 Electrical information
35	Not issued

## SERVICE RELEASE

- 2 -

NO.		<u>NATURE OF RELEASE</u>
36		Cylinder barrel interchangeability
37		Effect of Isolastic engine mountings
38	Not issued	
39		1971 warning light assimilator
40		1971 stand springs
4	1	Reissue of commando parts book
42		Timing cover replacement
43		Change of spark plug grade
44		Slack shock absorber paddles
45		Inlet valve guide replacement
46		Introduction of S. E. rings
47		Muffler replacement
48		Introducing new clutch cables
49		Fitting exhaust systems
50		Introduction of tougher kick start pawl
51		Clutch cable recommendation
52	Not issued	
53		Cylinder head Torque Settings
54		Rear Brake drum oil seal
55		Inlet valve guide oil seals
56		Fouling between H.T. leads and head steady
57		Maintaining Isolastic adjustment
58		Engine bearer nuts
59		Revised airbox/battery tray
60		Oil pump replacement
61		Use of Commando gears on earlier models
62		Damage to oil pipe by chafing
63		Exhaust pipe lockrings
64		Heat damage rear wheel cushdrive
65		Security of rear brake drum bearing circlip
66		Cancelled
67		Rear hub disc protective coating
68	Re issued	Revised main bearings
69		Summary of oil consumption causes

## SERVICE RELEASE

- 3 -

<u>NO.</u>	<u>NATURE OF RELEASE</u>
70	Disc brake preparation
71	Introduction of battery breather tube
72	Interchangeability of exhaust pipes (INT)
73	Exhaust System (SS)
74	Front brake H.P. modification
75	Clutch adjustment
76	Copper washers at rocker plates
77	1972 Camshafts and bushes
78	Frame checking dimensions
79	Cylinder head tightening sequence
80	Changing oil in front forks
81	Disc brake wheel spokes

I N D E X

	SERIES 2 DISTRIBUTOR AND DEALER ONLY	SERIES 3	GENERAL
01	Mods to exhaust valve guides	Tyre pressure recommendations	
02	Clutch Plate Oil Grooves	Fuel Requirements	
03	Combat Valve Springs	Reversal of H/bar Switches	
04	Std. and Commando pistons and O/S	Method of Service Release Issue	
05	Disc Brake Conversion Kit	Availability of Serv. Wall Charts	
06 Re-Issued	Crankshaft Main Bearings	Retention of Shock Abs. Segments	
07	Removal of Inhibitor	Interchangeability of Prop Stands	
08	Hydraulic Steering Damper Kit - Part No. 064247	Water in Front Brake	
09	Crankshaft Main (Roller) Bearings	Rider Instructions. Petrol Taps Off	
10	Extra High Capacity Main Bearings	Isolastic Shimming	
11	Achieving Legal Noise Levels	Silencer Mute	
12		High Performance Parts List	
13		Camshaft Interchangeability	
14		Revision to SR 3/10	
15		Security of Battery in Carrier	
16		Oil in Timing Case	
17			
18		Battery Location & Detention	
19		"Majorca" European Type Low Handlebars 064887	
20		Positive Location of Engine Mounting Buffers	
21		Cylinder Head Gasket	
22		Swinging Arm Pivot Spindle 064077	
23		Cylinder Head Interchangeability	
24			

I N D E X

	-SERIES 2 DISTRIBUTION AND DEALER ONLY	SERIES 3	GENERAL
25		"Quick Action" Throttle Twistgrip 064600	
26		Pannier and Luggage Equipment	
27		Introduction of "Veglia" Instrumen	
28		Improved Clutch Capacity	
29			
30		Battery Preparation Prior to Installation	
31		Removing Auto-Advance Mechanism	
32		Wheel Balance Weights	
33		Inlet Valves Incorporating Stellite Tip	
34		Rear Brake Shoes & Slippers	
35		Con-Rod Big-End Shell "Packaging"	
36		Model 149 SA Ignition and Lighting Switch	
37		Front forks - Recommended Lubricant	
38		Top Engine Mounting - Engine Steady Plate.	
39		Replacement Centre Stand Kit	
40		Handlebar Switches	
41			
42		Swinging Arm	
43		Auto Advance Unit - Periodic Lubrication	
44		Front Wheel Disc Brake	
45		Front and Rear Tyre Fitment Procedure	
46		Recommended Assembly Sequence- Exhaust System	
47		Lubricating Oil Recommendations	
48		Carburettor Needle Settings	

I N D E X

	SERIES 2 DISTRIBUTION AND DEALER ONLY	SERIES 3	GENERAL
49		Symptoms of Pre-Ignition	
<b>50</b>			
51		Cylinder Head Steady - Recommended Assembly Sequence	
52		Improved Material "Cut-Out" Decals	
53		Rear Mudguard Mud-Flap	
54		Passenger Grab Rails	
55		Introduction of Rear Chainguard Extension	
56		1973 - 850 Model Commando - High Performance Modification Instructio	
57		Rear Chain Oiler Regulator Adjuster	
<b>58</b>		Lucas Auto-Advance Mechanism	
<b>59</b>		Recommended Engine Lubricants	
60		Front Brake Caliper Incorporating Stainless Steel Disc Scraper	
61		Rear Wheel Bearing Spacer	
62			
63		"Spin-On" Oil Filter Element 063371	
64			
65		Warranty Labour Allowance - 850 Mod	
66		Luggage Carrying & Pannier Equipmen	
67		Norton Villiers - Loctite Machinery Adhesive and Loctite Plastic Gasket	
68		Cylinder Head Gasket & Gasket Sealant Compound	

---

SERVICE RELEASE

NO. 3

NATURE OF RELEASE: Carburetter Specification Change.

MODELS AFFECTED: Commando

DISTRIBUTION: Home and Overseas

PARTS INVOLVED: Megaphone silencer

EXPLANATION: To meet recent U.S.A. legislation it has been necessary to introduce megaphone silencers modified to provide a lower noise level than the original megaphone type. The later type are modified by the fitting of a perforated tube in the end cone and their use necessitates the fitting of smaller main jets. The two types of silencer end cone are 'shown below:-

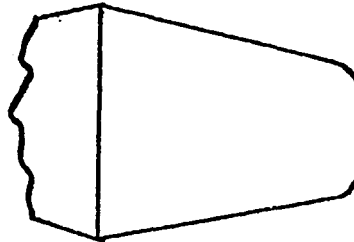

Early type

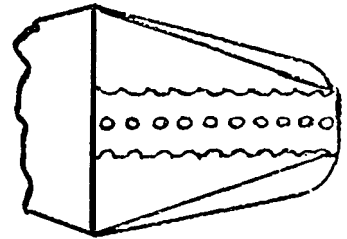

Late type

ACTION: Examine the megaphone silencer end cone. If this is hollow as the early type above, the jet size should be 220. If the end cones have a perforated tube as in the late type above, the main jet size should be 180.

Issued 25th March, 1970





motorcycles

## SERVICE RELEASE

### SERVICE RELEASE

NO: N4.

NATURE OF RELEASE: Gearbox Location.

MODELS AFFECTED: Commando (All conditions)

DISTRIBUTION: **Worldwide.**

PARTS INVOLVED: **14367** Top Fixing Bolt.

EXPLANATION: We find that operation of a **machino** with the top mounting bolt insufficiently tight **can** result in the gearbox moving under heavy load conditions, **causing** the primary chain to become excessively tight. **This** put<sup>8</sup> the goarbox mainshaft under a **severe** bending moment **which** ultimately could **lead to** a gearbox. failure.

ACTION: Re-adjust the primary chain by turning the adjustor<sup>8</sup> beyond the correct chain tension point and slackening back to achieve the recommended  $3/8''$  up and down movement of the chain. Raving done **so**, the bottom mounting bolt should be ro-tightened and the top bolt i-e-tightened to a torque of **70** lb. ft.

MAY, 1970.



motorcycles

## SERVICE RELEASE

NO: N.5

NATURE OF PROBLEM: Clutch slip.

MODELS AFFECTED: Commando (All Editions) from Eng. No. 132576.

DISTRIBUTION: Worldwide.

PARTS INVOLVED: 06-0749 Clutch Plate.

EXPLANATION: One piece clutch friction rings have been fitted to recent productions and there is a tendency for oil to build up on the friction surfaces causing clutch slip under some conditions.

ACTION: Remove the clutch friction plates, cut 12 radial grooves of 'U' section into the friction surfaces at both sides of each of these plates. The grooves should be 3/32" wide by 0.030" deep. The effect of this modification will be to break down the oil film on the friction plates.

MAY, 1970.

**SERVICE RELEASE**

NO. N6.

REASON FOR RELEASE: Incorrect assembly of front forks to frame.

MODELS AFFECTED: All Commando.

DISTRIBUTION: Worldwide.

PARTS INVOLVED: Front Fork Assembly.

EXPLANATION: During assembly of the fork lower lug and stem to the steering head tube of the frame, it is possible for the shoulder of the stem to become lodged against the lower headrace. If this is not realised and the fork should turn on to full lock, the thick cross section of the yoke will lodge against the lock stop on the frame. As the stem is drawn home into the bearings by tightening of the large stem nut, the yoke cannot follow and will either be distorted beyond further use or fractured in the area where the stem joins the yoke.

ACTION: To prevent damage, ensure that the correct lower portion of the stem is central in relation to the lower bearing inner race before the stem nut is tightened.

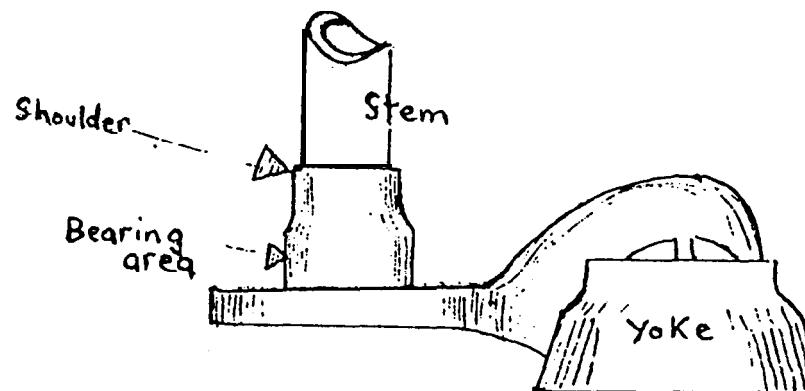

---

## SERVICE RELEASE

NO. N7.

NATURE OF RELEASE: Exhaust note.

MODELS AFFECTED: Commando Roadster.

DISTRIBUTION: U.S.A. Canada, Sweden.

PARTS INVOLVED: Modified megaphone silencers.

EXPLANATION: We are advised of sales resistance to machines fitted with the latest reverse cone silencers with perforated tubes in the end cones due to a whistling effect over subdued exhaust note.

ACTION: Using a 13/16" diameter sheet metal rotary cutter on an extended drill bit cut a hole through the blanking plate as shown below.

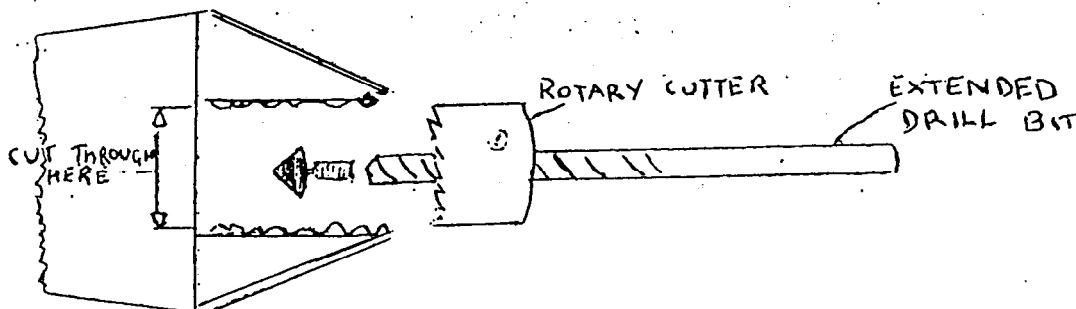

This modification makes it essential to change the main jets to 210 and to drop the needle in the clip to the top (No.1) groove. If carburation is not corrected after this silencer modification, severe damage will be caused. Observe that the resultant exhaust note still falls within legal requirements.



No: N9

motorcycles

## SERVICE RELEASE

NATURE OF RELEASE: Putting batteries into service.

MODELS AFFECTED: A1 1 Commando.

DISTRIBUTION: Worldwide

PARTS INVOLVED: Lucas batteries.

EXPLANATION: Experience has shown that a relatively large number of batteries are damaged by incorrect preparation or discarded as un-serviceable due to sulphating in the dry charged condition in shipment, whilst perfectly serviceable if given a suitable initial charge.

ACTION : With batteries and acid at a temperature of between 60 degrees F and 100 degrees F fill with acid S.G. 1.260 (temperate) or 1.210 (tropical). Read electrolyte temperature a few seconds after filling by inserting a thermometer into each individual cell in turn. After standing for 20 minutes individual cell temperatures are again read and the temperature rises noted.

The open-circuit voltage of the battery is then read using a good grade voltmeter.

If the temperature rise in any one cell or cells is not greater than 10 degree F and the open-circuit voltages not below 12.4 then the battery is ready for service.

If these limits are exceeded the battery should be charged at 0.8 amps until the on-charge voltage remains constant over three successive hourly readings and all cells are gassing freely.

Batteries which are older than 12 months before being filled for service should be charged at 0.4 amps until on-charge voltage remains constant for three successive hourly readings and all cells are gassing freely.

On machines shipped overseas, having dry-charged batteries and no sealing plug at the end of the manifold, the battery must be dealt with automatically as in paragraph above.

April, 1970

## SERVICE RELEASE

NO: N10.

- NATURE OF RELEASE: How to use camshaft oil seal guide.
- MODELS AFFECTED: All **Commando** with timing cover **C.B.** assembly.
- DISTRIBUTION: Worldwide.
- PARTS INVOLVED: 06-1359 Camshaft oil seal guide.
- EXPLANATION: When the timing cover is offered over the end of the camshaft, the oil seal at the contact breaker housing must pass over the large diameter of the camshaft. This invariably causes damage to the pressure lip of the seal. A special tool is provided in **the tool kit** to screw into the end of the camshaft and guide the seal home without damage.
- ACTION: Screw the service tool into the end of the camshaft, finger tight, before the timing cover is offered up. Smear the tool taper with clean oil and push the cover gently **into place** so that the seal slides easily over the tool and onto the camshaft. The tool has a screwdriver slot and can be removed simply at this stage.

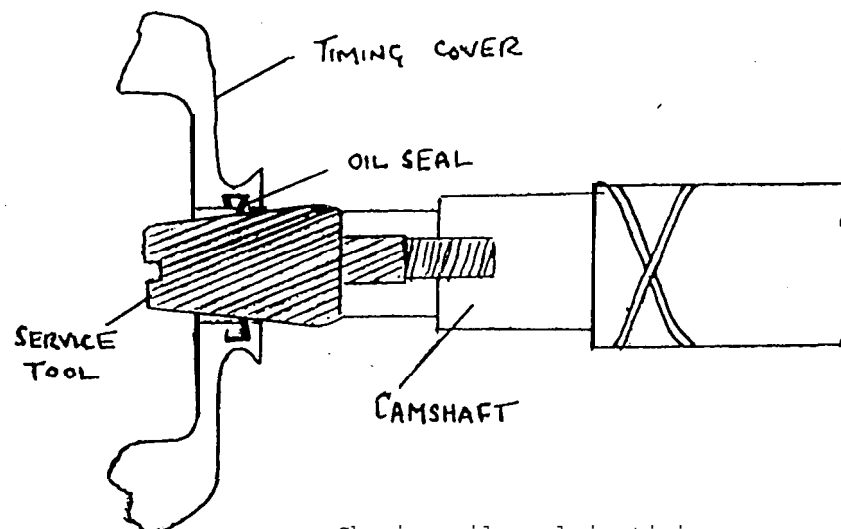

Showing oil seal in timing cover  
being slid over guide onto camshaft.



## SERVICE RELEASE

motorcycles

NO. N.11.

- NATURE OF RELEASE: Method of shimming Isolastic Mountings with the power unit in the Frame. .
- MODELS AFFECTED: All Commando.
- DISTRIBUTION: Worldwide.
- PARTS INVOLVED: Front and rear engine mountings.
- EXPLANATION: It is essential for the Commando power unit to be free on its mountings with clearance all round to prevent vibration. Similarly it is essential for freedom of movement to be controlled to close limits since the swinging arm is mounted on the rear engine plates and thus excessive side play would result in poor handling. Side movement is controlled by the use of shims fitted between the tube cap and spacer tube. Such shims are available in thicknesses of .005" in, .010" in, .020" in, .030" in. On the all-rubber mountings used from early 1969 onwards, the ideal shimming would be to produce .005" in. Free movement at both sides of the front and rear mountings with clearance all round the end collars. Manufacturing tolerances however may make it necessary to increase the free movement in individual cases to prevent transmission vibration. Under no circumstances should the mountings be assembled with nil clearances.
- ACTION: Before attempting adjustment with the unit in the frame, you should have available spare shims, a torque wrench, spanners for the mounting bolts, a long bar to lift the power unit in the frame, a soft metal drift and a long slave bolt.
- Slide back the plastic gaiters in turn and check free play with a feeler gauge between the polyurethane washer and end collar at each side. Record the measurements. Starting with the front mounting, remove the nut and, using the soft drift, tap the mounting bolt through until the gaiter, collar, polyurethane washer, tube cap and shims can be collected. Now slide the slave bolt into the mounting to support the unit as the mounting bolt is pulled free. Collect the gaiter, collar, shims etc., from this side then repeat for the other side. Measure the total thickness of shims used in the front mounting, subtract this from the gap checked before dismantling then select shims to permit an ideal of .005" in. clearance at each side. Divide the shims selected between the left and right sides, smear the shims with grease and than reassemble ensuring that the plastic gaiters are not too long so that they are trapped between the frame lugs and end collars. The gaiters may be trimmed carefully with a very sharp knife if necessary but do not remove excessive material or water and dirt ingress will occur. Note that the spindle nut must be torqued to 25 foot pounds. Now check that at no point is the collar hard on the mounting tube end cap. If it is, then remove shims a little at a time until there is clearance ALL ROUND.

Continued...

NO: N.11.

ACTION:

Check and rectify the rear mounting shimming by the same method until again there is free play all round. On the rear mounting it is even more important to allow *no* more free play than is absolutely necessary to achieve all round clearance.

JUNE, 1970.



## SERVICE RELEASE

NO: N.12

- NATURE OF RELEASE: Stiff Clutch Action.
- MODELS AFFECTED: Commando - All editions.
- DISTRIBUTION: Worldwide.
- PARTS INVOLVED: 060930 and 060919 Clutch Cables.
- EXPLANATION: Due to incorrect routing of the clutch cable there have been certain complaints of a stiff clutch action. This is not due to any shortcoming in either the clutch or clutch thrust mechanism but is purely attributable to the run of the cable.
- ACTION: Note the diagram below and re-route the clutch cable in accordance with this to eliminate any tight bends. On completion, run a little thin oil down the inner cable to ensure freedom of movement and the problem will be eliminated.

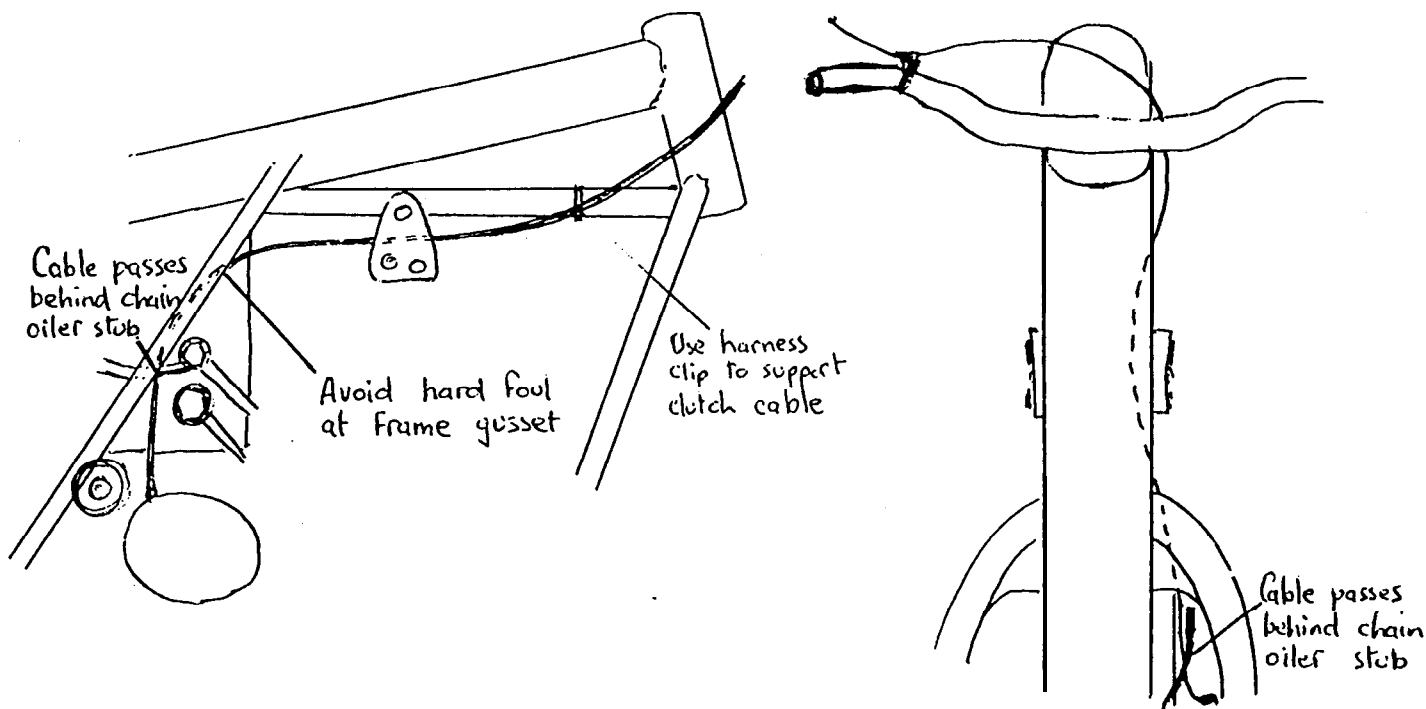

JUNE, 1970.



## SERVICE RELEASE

No. N.13

NATURE OF RELEASE: Excessive Oil Consumption

MODELS AFFECTED: Commando Models

DISTRIBUTION: Worldwide

PARTS INVOLVED: Taper Compression Rings

EXPLANATION: We are aware of a condition of severe over-oiling and previously some improvement has been achieved by the change of scraper ring type and more careful assembly of the scraper rings. However, a certain number of machines have still returned unsatisfactory oil **consumption** figures. As a result of intensive test rig and road tests, the problem has been pinpointed as a manufacturing discrepancy in the middle (taper faced) Piston Rings. After consultation with the ring manufacturers, a change in manufacturing techniques will prevent any reoccurrence on future rings to cope with any machines giving trouble in service, a revised form of piston ring is being made available immediately.

ACTION: On any machine returning an oil consumption figure heavier than 200 miles per pint, replace the middle ring on both pistons with the special ring 06-2262. It is essential to fit these rings correctly with the word "TOP" facing up wards so that proper oil control is gained. This special type of ring is identified by a chamfer on the inner diameter. We are confident that after this rectification the **over-oiling** problem will be overcome.

July, 1970.



motorcycles

## SERVICE RELEASE

NO: N.14

NATURE OF RELEASE: Removing Cylinder Head in Frame

MODELS AFFECTED: Al 1 Commando

DISTRIBUTION: Worldwide

PARTS INVOLVED: Cylinder Head and Fittings

EXPLANATION: It is **apparent** that there **is** some confusion amongst dealers and owners where it is considered impossible to remove the cylinder head with the engine in the frame, without removal of the cylinder block at the same time. The cylinder head can be removed and re-fitted with very little difficulty by the following means.

ACTION: Assuming all **ancilliary** equipment (gas tank, coil cluster, exhausts and mufflers, head torque stay, three rocker covers, rocker oil feed pipe and carburettors on manifolds) has been removed, slacken all rocker adjusters completely, remove five nuts below and five bolts above the cylinder head and separate the cylinder head from the cylinder block - if necessary a light blow under the exhaust ports on the head with a hide mallet will dislodge the head. All that now prevents the head from being lifted clear is the presence of the pushrods. A second operator is now required, the first to lift **the head whilst** the second lifts all four **pushrods** clear of the rocker arms which are then pivoted well clear of the valve stems allowing the **pushrods** to slide past into the rocker box portion of the head. The **pushrods** will lift sufficiently to clear the cylinder block whilst the head is lifted out to one side, clear of the frame.

Reassembly requires a similar technique with the **pushrods** recessed as far as possible into **the** cylinder head. The longer **pushrods** are the inlets and are fitted inboard. As the head is slid into position between the cylinder block and frame rails the **pushrods** are **dropped** through the **pushrod** tunnels and **located** on the cam followers. The head is then lowered into position and if necessary the rocker ball ends **can** be engaged with the tops of the pushrods.

July 1970



**SERVICE RELEASE**

No. N.15

NATURE OF RELEASE: Routine check on Oil Pump

MODELS AFFECTED: Commando - All Editions

DISTRIBUTION: Worldwide

PARTS INVOLVED: 15511A - Oil Pump Spindle Nut

EXPLANATION: During routine work which necessitates removal of the timing cover, it is recommended that a check be made on the security of the oil pump spindle nut - that is the nut securing the straight cut pinion on the front of the oil pump. We have encountered isolated instances of the nut failing to tighten completely due to the Woodruff Key protruding fractionally beyond the pinion.

ACTION: If there is any evidence of the nut slackening, remove the oil pump complete. Remove the spindle nut and, using a claw type extractor if necessary, remove the pinion. Lift out the Woodruff Key and reduce the length with a file so that, on reassembly, the key cannot protrude beyond the pinion, thus preventing the nut from tightening.

July, 1970



motorcycles

## SERVICE RELEASE

NO: N.16.

NATURE OF RELEASE: Adjustment procedure for Stop Light Switch

MODELS AFFECTED: Commando - All Editions

DISTRIBUTION: Worldwide

PARTS INVOLVED: 031621 Stop Light Switch

EXPLANATION: If the stop light switch is positioned incorrectly, it becomes the stop for the rear brake pedal with the result that the plastic body fractures. A simple adjustment procedure as outlined below will prevent such damage.

ACTION: Slacken the nuts and screws holding the switch, to the plate with slots, on the brake pedal. Set the rear brake pedal to suit the riders preference - this is done by adjustment of the stop bolt and locknut. Adjust the rear brake cable to the desired setting. Move the switch up, a little at a time, until the switch plunger is central to the abutment and until the least depression of the pedal causes the stop light to illuminate. Nip up the switch securing screws and allow the pedal to return to rest, ensuring that the switch is not fully compressed before the pedal stop is reached.

JULY, 1970.



motorcycles

## SERVICE RELEASE

N17

NATURE OF RELEASE: Horn adjustment.

MODELS AFFECTED: All Commando.

DISTRIBUTION: U.S.A. only.

PARIS INVOLVED: 032010 Horn.

EXPLANATION: To meet Federal Legislation it is necessary for the horn to be kept in proper adjustment. There is an adjuster screw with locknut for this purpose, working on to the centre of the horn diaphragm. The horn is mounted just above the swinging arm pivot. If there is any doubt that the horn is working at full efficiency, it must be dismantled from the motorcycle since there is insufficient room for adjustment in situ.

ACTION: The horn should be mounted by the bracket in a vice whilst adjustment is carried out. Connect one horn terminal to a 12 volt battery in a good state of charge. Now touch a lead from the other battery terminal to the second horn terminal. This should be momentary contact only, not sustained contact which could damage the horn. The horn should sound loud and clear but if it does not, hold the slotted adjuster with a screwdriver and slacken the large hexagonal locknut. Now, by turning the adjuster in or out in 1/16" intervals and sounding the horn each time, the best position will be found. Hold the adjuster whilst the locknut is tightened and finally check that adjustment has not been lost, by sounding the horn again. If all is well, the horn can be refitted on the motorcycle.

August 1970.



motorcycles

NO: N.18

## SERVICE RELEASE

CATEGORY OF RELEASE. 3 (See over)

- NATURE OF RELEASE: Stiff Clutch Action.
- MODELS AFFECTED: All Commando.
- DISTRIBUTION: Worldwide.
- PARTS INVOLVED: 064715 Clutch Operating Arm.
- EXPLANATION: Following Service Release N.12 on this subject, we learn that in some cases dealers have been fitting the ATLAS clutch arm 040029, in lieu of the Commando clutch arm 06-0715 in an attempt to cure stiffness. The ATLAS arm is unsuitable for the diaphragm clutch of the Commando since it provides insufficient lift. This results in clutch drag and in order to compensate, the tendency is to take up clutch free play and clutch slip will result. The polishing operation on the Commando clutch arm has been improved on production and this has given a much better clutch action.
- ACTION: Where the problem of stiffness persists after the clutch cable route has been improved, remove the gearbox outer cover to gain access to the clutch arm. Relieve the end track of any burrs or roughness and burnish, First with a coarse, then a very fine grade of emery paper. Ensure that the body on which the clutch arm pivots has not turned as the locking ring has been tightened. If it has, the clutch arm will not move vertically and the clutch cable will distort as the operating arm pivots. To reposition, slacken the locking ring, turn the body as required and re-tighten the ring. Reassemble clutch arm with a smear of grease on the end track.

AUGUST, 1970.



motorcycles

## SERVICE RELEASE

NO: 19.

CATEGORY OF RELEASE: **4 (See Over)**

NATURE OF RELEASE: Operation of Steering Lock.

MODELS AFFECTED: All Commando.

DISTRIBUTION: Worldwide.

PARTS INVOLVED: **030175** - Steering Lock and Keys.

EXPLANATION: Would all concerned please note that the steering lock is intended to be operated with the handlebars turned fully to the right. Locking in any other position, whilst rendering the machine useless to a prospective "joy rider" type of thief, does not provide a sufficient deterrent to the more serious thief who would find illegal removal facilitated by the ability to manoeuvre either left or straight ahead. Riders should also be cautioned on the potential danger of immobilising the motorcycle in such a **way** that it could still be driven in a straight line.





motorcycles

## SERVICE RELEASE

NO: N.20

CATEGORY OF RELEASE: 3/4 (See over)

MODELS AFFECTED: All Commando

NATURE OF RELEASE: Timing cover gasket interchangeability .

DISTRIBUTION: Worldwide (Information for general use)

PARTS INVOLVED : Timing cover gaskets, T2236, 060719, 061092.

EXPLANATION : On **all** Commando engines, the pressure release valve in the timing cover discharges surplus oil through a **drillway** in the timing cover and crankcase back to the inlet side of the oil pump, instead of merely allowing it to escape through an open hole into the timing chest as on all earlier Norton twin cylinder engines.

**As this drillway crosses** the timing cover to crankcase joint face, the gasket used must have an additional tab or loop to seal it and gasket part number **T2236 does not have this**. Therefore T2236 must not be used in any Commando engine. We learn that certain spurious gasket sets currently available and identified as suitable for the Commando contain a timing cover gasket to the T2236 form which is quite unsuitable.

Commando timing cover gaskets 060719 and 061092 differ in that 061092 is intended for engines with the camshaft driven contact breaker and thus has an additional tab or loop to seal the **drillway** for the contact breaker low tension feed wire..

**It** will be noted from the above that 061092 gasket will service all previous Norton twin models **7,77,88,99**, 650 and Atlas. This gasket is thicker than previous conditions and effects the compression of the rubber seal between the oil pump outlet and timing cover.

ACTION : Before renewing a Commando timing cover gasket, make sure that it connects and prevents leakage at all holes in the joint Face.

Using the thicker **061092** it may be necessary to shim up the rubber seal at the oil pump to achieve 0.010" of compression through in the majority of cases it will be found that the correct compression is achieved by the use of the seal without shims.



## SERVICE RELEASE

motorcycles

No. N.21

CATEGORY OF RELEASE: 6 (see over)

NATURE OF RELEASE: Distribution of Service Releases

DISTRIBUTION: Worldwide (Trade only)

EXPLANATION: We are on occasion being faced with claims for replacement of parts on the strength of information given in Service Releases which we have circulated purely for the guidance of our Franchised dealers. There is no wish on our part to restrict information which is widely and usefully applicable but at the same time a great deal of useful information would be barred to dealers were we to circulate only that information which could be made generally available without implication. Service Releases will from now on be classified in "Distribution" as "Trade Only" or "Suitable for Release to Owners."

ACTION: Before circulating information from Releases check the distribution. This is in your own interests since any claim resulting from the disclosure of "TRADE ONLY" information must become the responsibility of the dealer involved.

September, 1970



motorcycles

## SERVICE RELEASE

NO: N.22

CATEGORY OF RELEASE: 3 (See Over)

NATURE OF RELEASE: Incorrect routing of rocker oil feed pipe.

MODELS AFFECTED: All late Commando with flexible rocker pipe.

DISTRIBUTION: Worldwide. - Trade Only.

PARTS INVOLVED: Flexible Rocker Feed Pipe.

EXPLANATION: On the introduction of the flexible rocker feed pipe, the overall length of the pipe has been increased. Some 100 machines are known to have left the factory with the pipe routed incorrectly so that fretting could occur between the oil pipe and banjo and the right side of the rocker box. Potentially under these conditions the pipe may fracture after a period of use.

ACTION: Examine all the machines with the flexible rocker oil feed pipe. The pipe should pass from the take off banjo on the rear of the timing cover, through the gearbox aperture in the rear engine plate, then between the rear engine plates, and between the carburettor manifolds to the right side of the rocker box. Be careful to give clearance between the pipe and the rocker spindle end cap bolts at this point. The branch pipe to the left side passes over the top of the rocker box forward of the cylinder steady. Make sure that the pipe does not come into contact with the head steady.

OCTOBER, 1970.



motorcycles

## SERVICE RELEASE

NO: N.23

CATEGORY OF RELEASE: 5NATURE OF RELEASE: Spares NotesMODELS AFFECTED: VariousDISTRIBUTION: Worldwide (Trade Only)

Please note the following:-

- (1) ATLAS Cylinder 242378 serviced by: 060396A Cylinder 1 off  
 (up to eng, No.114869) 25494 Ring 2 II  
 060401 Bolt 4 II  
 060400 Head Gasket 1 "

The top spigots of the early ATLAS cylinders occupied a recess in the cylinder head. When the Commando cylinder is used, the rings fill the spigot recesses in the head. Open out the four bolt holes in the cylinder head to accomodate the thicker bolts.

- (2) ATLAS cylinder 25323 serviced by: 060396A Cylinder 1 off  
 (from eng. No.114870) 060401 Bolt 4 "  
 060400 Head Gasket 1 "

Open out the four bolt holes in the cylinder head to accomodate the thicker bolts.

- (3) We have ceased to supply front brake linings 060812 as separate spares requirements due to the fact that linings must be ground to size after fitting. We now only stock brake shoe complete with lining 060006.
- (4) It is most important for the required standard colour to be stated when ordering Fuel Tanks, Oil Tanks, Side Covers and Tail Fairings. The colour should be suffixed to the part number VIZ "061108 RED."
- (5) On plated parts where there has been an alternative finish ie: chromium or cadmium suffix the finish required.

OCTOBER, 1970.



SERVICE RELEASE

motorcycles

No. N.24  
Revised

CATEGORY OF RELEASE: 4 (See over)

NATURE OF RELEASE: Reconditioning oil pumps

DISTRIBUTION: UK only (for general distribution)

EXPLANATION: We regret that the only type of oil pump we are now able to recondition is the one common to all Norton **Twin** models, 650, ATLAS, **P11**, P11a, **N15** and Commando from engine no. 116372.

Since we no longer offer the facility for other pumps, we regret that other types received by Service Department must be returned as received.

December, 1970



motorcycles

NO: N.25

## SERVICE RELEASE

CATEGORY OR RELEASE: 4 (See Over)

NATURE OF RELEASE: Identifying marks on assemblies.

DISTRIBUTION: Worldwide (Trade Only)

EXPLANATION: From queries received we gather that our system of stamping a Factory identification symbol on certain assemblies (for example: the marking "X" on the top of the rear engine mounting boss) is causing some confusion.

We respectfully point out that such markings are purely a Factory Facility to enable us to keep track of any production changes without the need for stripping. Such markings **will** appear only for a **limited time** and then disappear whereas the feature **may** well continue. As such, we **shall** only make known the purpose of markings where we feel common knowledge is mutually advantageous, One such example is given **below:-**

MARKING: "X" stamped on top of rear engine mounting boss.

PURPOSE: To identify for fitting on assembly, engines with the modified middle piston ring (Service Release No: N.13 refers). In view of the temporary nature **of this marking, all that can be inferred is that** any engine with the "X" has the modified middle rings and in the unlikely case of overcoiling, the cause lies elsewhere.

NOVEMBER 1970



## SERVICE RELEASE

motorcycles

No. N26

<u>CATEGORY OF RELEASE:</u>	4 (see over)
<u>NATURE OF RELEASE:</u>	Clutch slip
<u>MODELS AFFECTED:</u>	All Commando
<u>DISTRIBUTION:</u>	Worldwide (For general distribution)
<u>EXPLANATION:</u>	<p>It is apparent that primary chaincases are being overfilled by some owners, giving rise to clutch slip. The oil level should always be checked by using the level plug located on the front surface of the primary chaincase in line below the chaincase fixing bolt. With the level plug removed add the recommended grade of oil through the filler hole until it starts to trickle from the level hole. When this stage is reached, allow any surplus oil to drain and then refit the level plug and filler plug. The level is now correct.</p> <p>Clutch slip can be caused by incorrect free play on the clutch push rod or lack of free play on the clutch cable. To adjust, slacken off as far as possible the cable adjuster at the handlebars control. Remove the large slotted plug on the primary chaincase to gain access to the diaphragm spring centre adjuster locknut. Slacken the locknut and then, using a screwdriver, screw the slotted adjuster gently home until contact with the clutch push rod can be felt. At this stage unscrew the adjuster one quarter turn. Now, holding the adjuster with a screwdriver to prevent movement, tighten the locknut fully. Clutch push rod adjustment is now correct and the plug in the chaincase can be replaced. Ensure that the cable and lever pivots are lubricated and that there are no tight bends in the cable. The final operation is to adjust the cable free play at the handlebar lever to 1/16" to 1/8".</p> <p>If these steps have been taken and slip continues, providing the friction plates are not worn severely or charred, the small clutch drive pins between the steel back plate and housing may have sheared. This in effect causes the clutch to function less one friction plate. Special hardened steel pins are used which must only be replaced by genuine Norton spares, part number 06-0756.</p>

December, 1970.



motorcycles

## SERVICE RELEASE

No. N.27

CATEGORY OF RELEASE: 4 (See over)

NATURE OF RELEASE: Claims for shortage in transit

MODELS AFFECTED: A1 1 Commando

DISTRIBUTION: Worldwide (TRADE ONLY)

EXPLANATION: Some time ago as a measure to counter increasing claims for shortshipment, we introduced an item by item contents check list, This list is completed by the packing inspector as the last operation before the crate front is fitted, Since introducing the list, claims have reduced noticeably but we continue to receive claims from some sources for shortages on items shown on our records as having been packed.

In order that we can investigate the cause, would any dealer or distributor raising a claim for short shipment, please ensure that the packing list is submitted with the claim. We regret that, as of now, any claim not accompanied by the packing list must be disallowed for the reason that we are unable to check the validity of the claim.





---

 SERVICE RELEASE

motorcycles

NO. N28

CATEGORY OF RELEASE: 4 (See over)

NATURE OF RELEASE: Cam chain tension

MODELS AFFECTED: Commando with cam driven contact breaker

DISTRIBUTION: Worldwide (for general distribution)

EXPLANATION: It is found that slackness of the cam chain can result in snatch, jarring shocks being delivered to the contact breaker and auto advance mechanism. This causes premature wear on these parts. We specify that the chain tension should be checked at 5000 mile intervals but, naturally, any obvious slackness evidenced by noise in this area should be taken up, irrespective of mileage. Adjust the cam chain tension to between 1/8" and 3/16" slack (that is, up to down movement) on the top run of the chain. To do this necessitates removal of the contact breaker and auto advance mechanism (use the withdrawal bolt 06-0934 for the auto advance cam). Next take off the timing cover, and the cam chain and slipper tensioner are exposed. The oilway exposed by removal of the cover must be blocked by one of the timing cover screws (see owners handbook) to prevent the loss of oil. Note that chain tension can only be adjusted correctly if there is no play in the intermediate spindle.

To check the chain tension, remove the sparking plugs so that the engine will turn easily and use a 9/16" Whit. socket or ring spanner on the camshaft sprocket nut and turn slowly anti - clockwise so that the lower run of the chain will be kept tight on the slipper and a true check of the tension can be made on the top run.

In this way the spanner will control the alternating load of the valve springs on the camshaft and it will be easy to find any tight spot to which the tension should be adjusted as described.

To increase chain tension, slacken the two nuts securing the slipper and lift it a little at a time, checking at each stage after nipping up the nuts whether the tension is correct. When the correct tension is achieved secure the slipper nuts to 180lb. in (15lb. ft).

It is most important when refitting the timing cover to use the camshaft oil seal guide 06 - 1359 to avoid damage to the seal in the timing cove?.



SERVICE RELEASE

motorcycles

NO. N30

CATEGORY OF RELEASE: 4 (see over)

NATURE OF RELEASE: Timing markings on rotor

MODELS AFFECTED: Late 1971 Commando (all models)

DISTRIBUTION: Worldwide (for general distribution)

EXPLANATION: The Lucas generator rotor now being received for production has two timing markings opposite each other. Dealers and owners should note that the presence of the surplus marking will not affect timing, either static or with a stroboscope.

To explain - the engine must be running for a stroboscope to be used. Setting the timing by the wrong marking would mean the spark was timed at **bottom** dead centre and the engine would not run. If the engine is timed on the correct stroke, the stroboscope will not pick up the wrong marking. Similarly with static timing, only the correct marking will align with the calibrated scale in the primary case with the piston near top **dead** centre on the Firing stroke for the cylinder being timed.

ACTION: Time ignition as previously instructed.

MARCH 1971



motorcycles

## SERVICE RELEASE

NO. N31

CATEGORY OF RELEASE: 4 (see over)

NATURE OF RELEASE: Breaking --in oil end oil changing

MODELS AFFECTED: All Commando

DISTRIBUTION: Worldwide (General Distribution)

EXPLANATION: As a result of development **experience** it has been found beneficial to speed up the initial **breaking** - in process **for** the engine unit. The recommended oils provide such a degree of **protection** that the rubbing surfaces require **an** extended period **to bed** satisfactorily. A different grade of oil **will in** future be used for initial bench **testing** of new engines and the nearest grade **commercially** available should be used for the **first** 500 miles.

At the 500 mile service it is most essential for the oil tank end crankcase filters to be cleaned out thoroughly during oil changing.

Use Castrolite for the initial fill of the oil tank. At the 500 mile service revert to the handbook recommendation.



motorcycles

## SERVICE RELEASE

No. N.32

CATEGORY OF RELEASE: 4 (see over)

NATURE OF RELEASE: Lubrication of rear brake drum bearing

MODELS AFFECTED : 1971 Commando (all models)

DISTRIBUTION: Worldwide (for general distribution)

EXPLANATION: 1971 models use an additional bearing in the rear wheel assembly, located in the rear brake drum. It is recommended in the Handbook that the wheel bearings be repacked with grease at 10,000 mile intervals. This figure is correct for all wheel bearings excepting that in the sprocket. The bearing in the sprocket requires more frequent attention due to the heat generated by the rear brake.

ACTION: Whilst examining the shock absorbing pads at 5,000 mile intervals examine also the sprocket bearing and if necessary repack with the recommended grade of grease. After, the rear wheel has been removed, leaving the sprocket in situ, it is only necessary to lift out the bearing spacer from the sprocket, followed by the dished washer and seal. The dished washer will be removed most easily with a small screwdriver blade. On reassembly, secure the dished washer by centre punching at each side.

March, 1971



---

## SERVICE RELEASE

CATEGORY OF RELEASE: 4 (see over)

No. N34

NATURE OF RELEASE: 1971 Electrical Information

MODELS AFFECTED: 1971 Commando (all models)

DISTRIBUTION: Worldwide (for general distribution)

EXPLANATION: A number of new electrical components have been introduced for 1971 models. We consider it essential for our dealers to be acquainted at an early stage with the positions of all electrical equipment. The 1971 wiring diagram and sheets describing the various items of equipment are attached.

January 1971

MASTER SWITCH.

Top front of left side panel. Access to terminals on Fastback/Interpol models with left (accessory) panel and shroud removed. On other models the terminals are accessible merely by sliding back the shroud. Switch controls ignition and lights.

LIGHT SELECTION SWITCH.

In top of headlamp. Switches from parking lights to full headlamp. To gain access to the terminals, remove headlamp front.

ALTERNATOR.

In forward portion of primary chaincase - windings resin encapsulated.

RECTIFIED.

Beneath dual seat to rear of frame cross plate. Leads accessible with dual seat off.

ZENER DIODE.

Mounted on rear of right footrest alloy mounting plate.

COILS.

Mounted on cluster bracket beneath fuel tank. To remove a coil, it is recommended that the fuel tank be lifted and the coil cluster removed complete.

CAPACITOR PACK.

Mounted to rear of coil cluster beneath fuel tank. Remove the coil cluster to gain access.

BALLAST RESISTOR.

Mounted on coil cluster bracket beneath fuel tank. Must remove cluster to gain access.

CHARGE LIGHT ASSIMILATOR.

Mounted in spring below frame top rails on coil cluster bracket. Must remove fuel tank to gain access.

FLASHER UNIT. (Optional - for direction indicators)

Beneath dual seat on frame cross plate.

HORN RELAY AND ALTERNATING HORN CONTROL BOX. (Interpol only)

Located in the left (accessory) cover.

Continued ....

POWER POINT.

On front plate of **airbox** - leads accessible without removing the **airbox** lid.

FUSE AND BATTERY.

Accessible when the left side panel is removed - 35 amp fuse fitted in negative lead in white plastic fuseholder.

STOP SWITCH FRONT.

Located in the front brake cable near back of headlamp.

HANDLEBAR SWITCH CLUSTERS.

Wiring not readily detachable at switches. Switch leads join the main harness at snap connectors beneath the fuel tank. Remove the fuel tank to gain access.

HEADLAMP.

Wiring connected to main harness beneath fuel tank which must be removed for access.

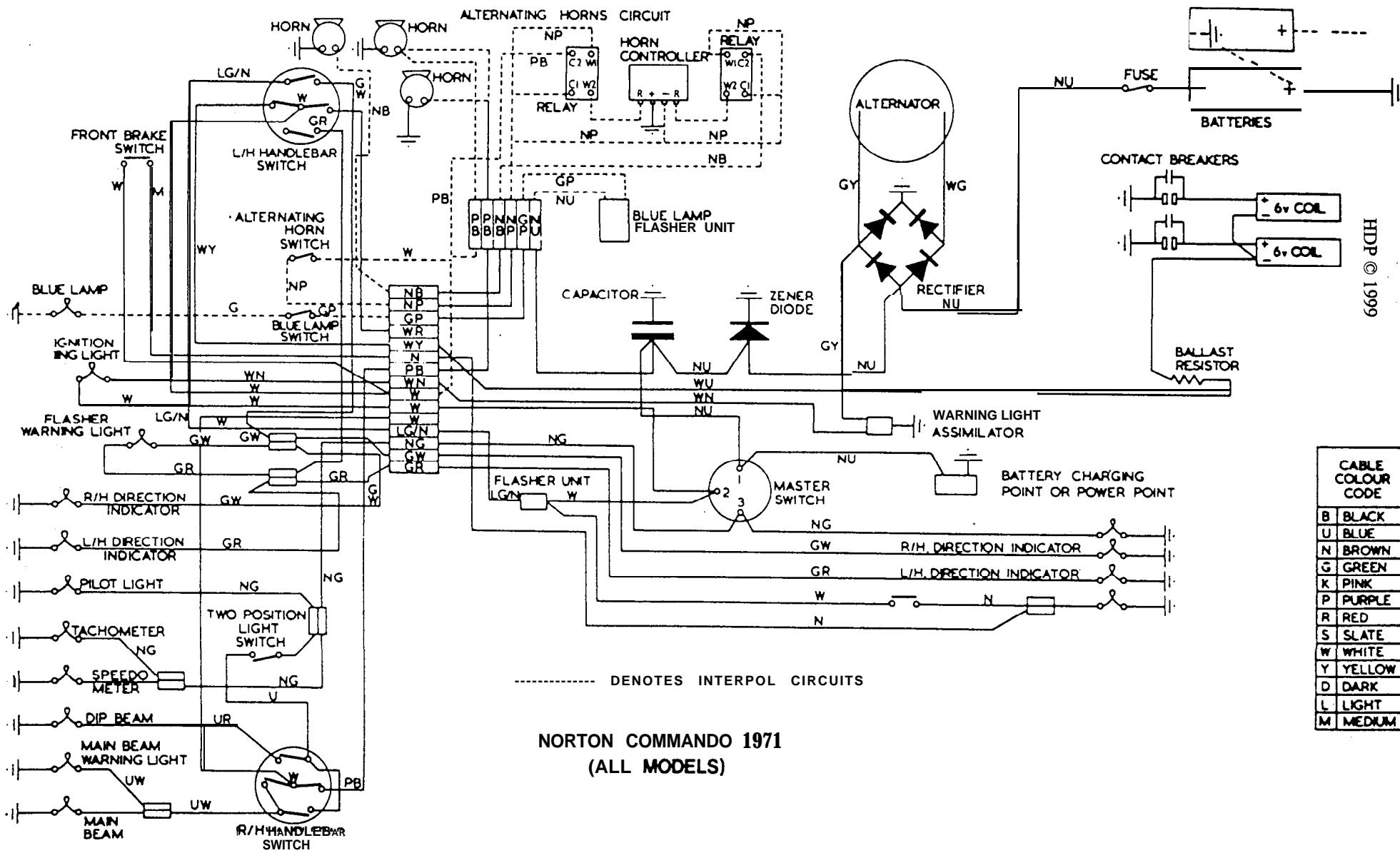

HDP © 1999

CABLE COLOUR CODE	
B	BLACK
U	BLUE
N	BROWN
G	GREEN
K	PINK
P	PURPLE
R	RED
S	SLATE
W	WHITE
Y	YELLOW
D	DARK
L	LIGHT
M	MEDIUM





motorcycles

## SERVICE RELEASE

No. N36

CATEGORY OF RELEASE: 5 (see over)

NATURE OF RELEASE: Cylinder interchangeability

MODELS AFFECTED: All Commando and Atlas

DISTRIBUTION: Worldwide (For general distribution)

EXPLANATION: A new cylinder 061705 has been introduced. This has larger cutaways at the bottom of each cylinder bore to facilitate the fitting of high performance camshafts.

The cylinder 061705 will replace cylinder 060396A and also, with the additional parts and information listed in service release N23, cylinders 24237A and 25323.

The latest cylinder will service all these previous conditions but previous conditions will not service the latest cylinder.



SERVICE RELEASE

No. N37

motorcycles

CATEGORY OF RELEASE: 4 (see over)

NATURE OF RELEASE: Effect of Isolastic engine mountings during servicing.

MODELS AFFECTED: 1971 Commando (all models)

DISTRIBUTION: Worldwide (for general distribution)

EXPLANATION: The patented engine mounting system allows for a certain amount of clearance between the engine/gearbox/swinging arm assembly and the main frame. For 1971 the centre stand is mounted directly onto the engine plates with the effect that the front wheel and the engine unit (through the centre stand) are in contact with the ground at the same time during servicing. This can result in some difficulty with accurate shimming of the mountings.

ACTION: During servicing operations such as shimming, it is recommended that the complete motorcycle is supported by a stand or stout box under the frame or footrests allowing the engine unit to be self-suspending and free from ground interference.

February 1971



motorcycles

# SERVICE RELEASE

No. N39

CATEGORY OF RELEASE: **3 (see over)**

NATURE OF RELEASE: Warning light assmulator

MODELS AFFECTED: 1971 Commando

DISTRIBUTION: Worldwide (for general distribution)

PARTS INVOLVED: Warning light assmulator **062054**

EXPLANATION: Instances have been reported of the charge warning light assmulator, being inoperative ie. the light has remained on when charging has been taking place. Investigation suggests that affected machines have had the leads to the assmulator connected incorrectly.

ACTION: Remove the fuel tank to gain access to the voltage assmulator connections. Ensure that the leads are connected as shown below.

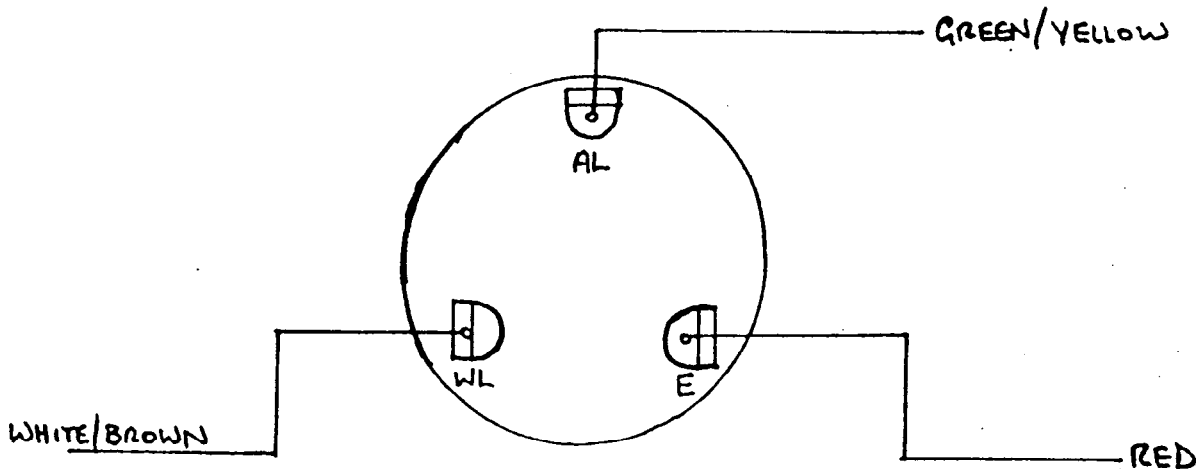



motorcycles

SERVICE RELEASE No. N42

CATEGORY OF RELEASE: 4 (see over)

NATURE OF RELEASE: Timing Cover replacement

MODELS AFFECTED: Early Commando with chain driven contact breaker

DISTRIBUTION: Worldwide (for general distribution)

EXPLANATION: It has been brought to our notice that severe engine damage has been caused on more than one occasion by the use of ATLAS timing cover 25187 as a replacement for the COMMANDO timing cover **o6-0716**. The reason is that the bleed back from the oil pressure release valve into the oil feed differs between ATLAS and COMMANDO. Use of the ATLAS cover on a COMMANDO crankcase. uncovers the release valve **oilway**, resulting in a severe loss of oil pressure.

ACTION: Ensure that whenever a timing cover is replaced, only the correct replacement is used.

February, 1972



motorcycles

SERVICE RELEASE

No. N43

CATEGORY OF RELEASE: 4 (see Over)

NATURE OF RELEASE: Change of spark plug grade.

MODELS AFFECTED: Commando - all models and gears.

DISTRIBUTION: Worldwide - general distribution.

EXPLANATION: A new grade of spark plug has been tested extensively (by this company) and found even more suitable than the present recommendation. The new grade - Champion **N7Y** replaces Champion **N6Y** and will in future be used as original equipment on all Commando models,

ACTION: It is not necessary to change the grade of plug on any machines. However, as the **N6Y** plugs reach the end of their useful life, they can be replaced to advantage with the **N7Y** grade.

June 1971



motorcycles

## SERVICE RELEASE

No. N44

CATEGORY OF RELEASE:

(as overleaf)

CATEGORY OF RELEASE:

2

NATURE OF RELEASE:

Slack drive pegs in rear brake drum.

MODELS AFFECTED:

1971 Commando engine numbers below.

DISTRIBUTION:

Worldwide - Trade Only.

PARTS INVOLVED:

062066 Rear Brake Drum.

EXPLANATION:

There is a possibility of the drive pegs in the rear brake drum working loose. The security of the drive pegs is easily checked by visual examination with the rear wheel removed. We recommend that every wheel be checked at the next service since the continued use of a motorcycle with slack drive pegs can result in considerable damage and expense at a later stage. Brake drums especially rechecked for drive pegs security prior to despatch from the factory are marked by either a white paint marking or the symbol 'WWW'. The white paint marking appears on the brake drum periphery adjacent to the sprocket : the 'WWW' marking is stamped on the periphery nearer the drive pegs.

ACTION:

Remove the complete rear wheel and separate the rear brake assembly. Take the brake plate assembly from the brake drum. The drive pegs are brazed into the drum. Examine most carefully to ensure that the brazing material has 'run' completely all round the drive peg bosses, when viewed from inside the drum. If there is any doubt whatsoever that the brazing operation has been successful, re-secure following the following instructions :

The paddle areas of the drum should be degreased most thoroughly by the use of any organic solvent such as trichlorethylene or carbon tetrachloride.

The shock absorber paddles must be examined for damage. If in sound condition, mask the drum braking area with 2 thicknesses of masking tape and re-secure the drive pegs from the inside only by manual electric arc welding using welding rods of the type McKay No.312 (North America) or type Stubbs 65 elsewhere.



motorcycles

## SERVICE RELEASE

No. N45

<u>CATEGORY OF RELEASE:</u>	3 (see over)
<u>NATURE OF RELEASE:</u>	Inlet valve guide replacement.
<u>MODELS AFFECTED:</u>	Commando - all years and models
<u>DISTRIBUTION:</u>	Worldwide (Trade Only)
<u>PARTS INVOLVED :</u>	Inlet valve guide (old part No. NMT 2011)
<u>EXPLANATION:</u>	<p>New valve guides 062725 fitted with plastic guide-to-stem seals 062726 have been introduced for the inlet valves only of Commando models. The existing valve guides NMT 201 continue for exhaust applications.</p> <p>The new valve guides are similar to the existing guides except for the provision of a groove above the valve guide collar. The groove is to locate the new oil seal. The latest inlet guides for inlet applications only.</p> <p>The seals are introduced to prevent oil passing between the guides and valve stems and being burnt, causing excessive oil consumption. Under no circumstances must the seals be fitted to the exhaust valve guides.</p>
<u>ACTION:</u>	<p>On any motorcycle with an oil consumption problem which shows clear evidence of over oiling via the inlet valve guides (ie. with obvious wetness on the area of the valve head adjacent to the valve guide) replace the inlet valve guides with part number 062725 (2 off) and add seals 062726 (2 off) to the new guides. This necessitates removing the inlet valves, springs etc., Heat the cylinder head to 90°F whilst driving out the old guides with a suitable shouldered drift and fit the new guides in a similar manner. If the valve stems are scored the valves must also be replaced, as this will render the seal ineffective. After fitting, the valve seats must be recut with a 45° cutter and the valves will need to be re-ground to the seats.</p>

May, 1971.



motorcycles

## SERVICE RELEASE

No. N46

CATEGORY OF RELEASE: 4

NATURE OF RELEASE: Introduction of "S.E." piston rings (oil control)

MODELS AFFECTED: 1971 Commando - all models  
Engine numbers: 146584 - 147176  
147259 onwards

DISTRIBUTION: Worldwide (for general distribution)

EXPLANATION: Spring expander type oil control rings have been introduced on the motorcycles specified above. The piston bodies are revised to accommodate the spring expander type of ring and for this reason it is not possible to use the later rings on an earlier piston or vice versa. For spares purposes the revised pistons with rings as a pair can be used to advantage on previous Commando models. It is not considered good practice to assemble an engine using one old type and one new type piston. The part numbers of the old and new components are detailed below:

Item	Old	New
Piston Complete L.H.	061185	062459
Piston Complete R.H.	061186	062462
Oil Control Ring	061180	062461

ACTION: When replacing pistons or piston rings ensure that the correct parts are used as detailed above.

June 1971





motorcycles

---

## SERVICE RELEASE

No. N47

CATEGORY OF RELEASE: 4

NATURE OF RELEASE: Muffler replacement

MODELS AFFECTED: Commando - 1970 Roadster

DISTRIBUTION: Worldwide except Australia (for general distribution)

EXPLANATION: We are no longer able to supply the 1970 type muffler 061608. With immediate effect orders for this type will be met by part number 061978. The latest silencer 061978 requires a 220 main jet whereas earlier types used variously 220, 180 then 210 main jets.

ACTION: When replacing an unserviceable muffler of the megaphone type with the later type, check the **carburetor** main jet size on the effected cylinder. Since it is bad practice (though physically possible) to use two mufflers of differing internal characteristics with different jet sizes on one motorcycle, it is strongly recommended that the mufflers are replaced as a pair, and the jet sizes adjusted accordingly.

June 1971



motorcycles

## SERVICE RELEASE

No. N48

CATEGORY OF RELEASE:

(As overleaf)

CATEGORY OF RELEASE:

4

NATURE OF RELEASE:

Introduction of new clutch cable.

MODELS AFFECTED:

Commando 1971 all models.

PARTS AFFECTED:

062813 and 062814 clutch cables.

DISTRIBUTION:

Worldwide (for general distribution)

EXPLANATION:

As a further refinement to 1971 models, a nylon lined clutch cable has been introduced which provides a greatly improved clutch action. There are 2 conditions of the nylon lined cable - 062814 for the Hi-Rider model only or 062813 for all other models.

The new cable provides a very much smoother clutch action for only a modest increase in cost. This cable is introduced only as a 1971 refinement, therefore 062813 can be used to service only 1971 models or previous models with Norton style semi Western (U.S.A.) handlebars.

June 1971



motorcycles

## SERVICE RELEASE

CATEGORY OF RELEASE: (as overleaf)

No. N49

CATEGORY OF RELEASE: 4

NATURE OF RELEASE: Fitting Exhaust Systems.

MODELS AFFECTED: All Commando models.

DISTRIBUTION: Worldwide (For general distribution)

EXPLANATION: If the exhaust system is not assembled correctly to the frame, it can lie in the wrong plane. The tendency is to push the system to its lowest position during fitting so that the centre stand and other equipment can come into contact with the exhaust pipe and mufflers. Assembly as below will prevent both misalignment and strain on any of the fittings.

ACTION: When assembling an exhaust system. Fit the copper / asbestos sealing ring into the exhaust port, after the exhaust pipe to the port and, holding in the correct position, tighten the **lockring** sufficiently to hold the exhaust pipe in the correct position whilst permitting it to be rotated slightly. Now assemble the muffler to the exhaust pipe and to the muffler mountings.

As the final operation tighten completely the muffler mountings, forward clip and lockring.

June, 1971



motorcycles

---

## SERVICE RELEASE

CATEGORY OF RELEASE:

(As overleaf)

No. N50

NATURE OF RELEASE:

Introduction of tougher kick start pawl.

MODELS AFFECTED:

Commando - all models

DISTRIBUTION:

Worldwide (Trade Only)

EXPLANATION:

A new material kickstart pawl has been under test for some time under arduous conditions. and has been proved completely satisfactory. The new pawl has been fitted to production motorcycles from engine number 147846. The part number 062015 is retained for the latest pawl but one side of the latest pawl is stamped with the letter 'M' or a center pop mark.

ACTION:

When replacing a worn kickstart pawl on any Commando use the latest pawl with the 'M' or center pop identification.

July, 1971



motorcycles

SERVICE RELEASE

CATEGORY OF RELEASE

'(as overleaf)

No. N51

4

NATURE OF RELEASE:

Clutch cable recommendation

MODELS AFFECTED

Commando 1971 all models

PARTS AFFECTED:

062813 and 062814 clutch cables.

DISTRIBUTION:

Worldwide (Trade **only**)

EXPLANATION:

Due to a certain amount of customer resistance to the relatively stiff clutch action of the Commando, it is recommended, though not mandatory, that the nylon lined clutch cables referred to in Service Release N48 be fitted to any new models in stock prior to supply.

For reference, the nylon lined cables are available under part number 062813. For all models other than Hi-Rider and part number 062814 for Hi-Rider only.

July, 1971



motorcycles

## SERVICE RELEASE

CATEGORY OF RELEASE: (as overleaf)

No. N53

4

NATURE OF RELEASE: Cylinder head torque settings

MODELS AFFECTED : Commando - all years and models

PARTS EFFECTED: Cylinder head bolts and nuts

DISTRIBUTION: Worldwide (for general distribution)

EXPLANATION: From the number of queries received on the subject, it is apparent that the recommended torque settings are not being adhered to. To prevent leakage at the cylinder head gasket, oil leakage and distortion, it is most important that the figures below are used at all times during assembly and rechecked periodically:

Cylinder head bolts and nuts	$\frac{3}{8}$ in (3.68)	30 lbs/ft kg/m)
Cylinder head bolts	$\frac{5}{16}$ in (2.75)	20 lbs/ft kg/m)

July, 1971



motorcycles

SERVICE RELEASE

No. N54

CATEGORY OF RELEASE:

(as overleaf)

NATURE OF RELEASE:

Rear brake drum bearing oil sealing

MODELS AFFECTED:

1971 Commando

PARTS AFFECTED:

062073 Felt Seal

DISTRIBUTION:

Worldwide (Trade Only)

EXPLANATION:

Earlier in the season it was found necessary to reduce the period for greasing the rear hub bearing from 12000 to 5000 miles. Subsequent tests have resulted in improved sealing brought about by the use of a revised material seal, part number 062889.

ACTION:

During regreasing of the brake drum bearing at the 5000 mile interval, fit the later felt seal 062889. Thereafter, the greasing interval may be extended to the original 12000 mile recommendation.

JULY, 197-1.

## SERVICE RELEASE

No. N55

CATEGORY OF RELEASE:

3 (as overleaf)

NATURE OF RELEASE:Inlet **Valve Guide** Oil Seals.MODELS AFFECTED:

Commando - all years and models

DISTRIBUTION:

Worldwide (Trade Only)

PARTS INVOLVED:

Inlet valve guide seal 062726

EXPLANATION:

Service Release N45 detailed the introduction and fitting of new inlet valve guides with seals. We have subsequently **encountered** instances of the seals being fitted incorrectly.

It is most important for the lip of the seal to locate all round in the groove of the inlet valve guide. The illustration below shows the seal fitted correctly. If the lip is not located the seal **will** ride up and down with the valve stem rather than providing a wiping action to prevent oil passing between the valve and guide.

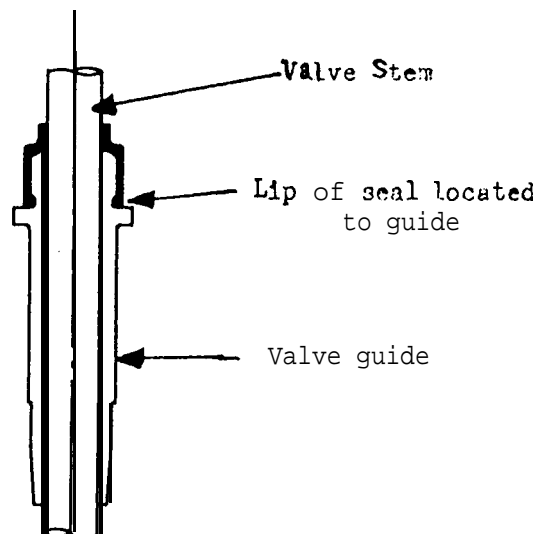





motorcycles

---

SERVICE RELEASE

CATEGORY OF RELEASE:

No. N56

NATURE OF RELEASE: Fouling between H.T. leads and head steady.

MODELS AFFECTED: **1971 Commando** - all models.

PARTS AFFECTED: 062263 H.T. Lead.

DISTRIBUTION: Worldwide (Trade Only)

EXPLANATION: If the H.T. (spark plug) leads are incorrectly routed, fouling takes place between the leads and cylinder head steady. Continued fouling will damage the insulation and cause shorting to ground (earth).

ACTION: Re route both H.T. leads to pass over, not under, the gross over portion of the rocker oil feed pipe.

JULY 1971



motorcycles

SERVICE RELEASE

CATEGORY OF RELEASE:

No. N57

NATURE OF RELEASE:

Maintaining Isolastic adjustment.

MODELS AFFECTED:

All Commando

PARTS AFFECTED:

Engine mountings.

DISTRIBUTION:

Worldwide (For general distribution)

EXPLANATION:

If shimming of the Isolastic mountings is not maintained to provide the correct clearances; vibration will be transmitted to the cycle parts and may lead to the failure of parts, by fatigue.

ACTION:

Maintain shimming at the mountings as detailed in service release N11. Ensure also that no accessories are rigidly mounted between the engine (transmission/swinging fork assembly and main frame which would render the Isolastic system inoperative.

AUGUST 1973



motorcycles

SERVICE RELEASE

No. N58

CATEGORY OF RELEASE: 4 (as overleaf)

NATURE OF RELEASE: Engine bearer nuts

MODELS AFFECTED: 1971 Commando

DISTRIBUTION: Worldwide (Trade Only)

PARTS INVOLVED: Engine stud nuts 060029 and 060348

EXPLANATION: Due to standardisation of nuts, for a short period only, nuts have been used on the engine studs which had a narrower facing. Service experience indicates that these nuts may slacken off in service and with immediate affect we are reverting to the original type. The unsuitable nuts have been in use for a very limited period and do *not* appear in the Commando Parts List.

ACTION: In any instance where the condition is encountered. Fit nuts 060029 and 060348 and there will be **no recurrence.**

SEPTEMBER. 1971



motorcycles

## SERVICE RELEASE

No. N59

CATEGORY OF RELEASE: 4 (as overleaf)

NATURE OF RELEASE: Revised airbox/battery tray fixings.

MODELS AFFECTED: All Commando 1971 from engine No. 150765

DISTRIBUTION: Worldwide (for general distribution)

PARTS INVOLVED: Battery tray/airbox backplate.

EXPLANATION: A new battery tray 062557 has been introduced. The new battery tray has provision for only 2 screws to secure the backplate instead of the previous 3. This modification is to improve airbox location. As and when stocks of a new airbox backplate 863053 are available, we shall introduce this onto production. Until then we shall continue to use the three hole type of backplate, packing this away from the battery carrier with spacers, and blocking the surplus hole, with blanking grommet 062845.

ACTION: When replacing either the airbox backplate or the battery tray as a spare part, ensure that (a) if one hole in the airbox backplate remains unused, grommet 062845 is fitted (preferably using a rubber type adhesive) or (b) that the "dimpled" type of backplate 063053 is used in conjunction with battery tray 062557.

SEPTEMBER. 1971



motorcycles

## SERVICE RELEASE

CATEGORY OF RELEASE: 5 (as overleaf)

No. N.61

NATURE OF RELEASE: Use of Commando gears on earlier models

MODELS AFFECTED: Atlas, Mercury, 650ss, 99, P11A,P11,G15,N15.

DISTRIBUTION: Worldwide (Trade only)

PARTS INVOLVED: Layshaft pinion 040284: mainshaft pinion 040422

EXPLANATION: Against orders for pre-Commando layshaft high gear pinion 040284 we supply part no. 061058. Similarly, orders for mainshaft high gear pinion 040422 are met with 061057.

CAPITAL: IT IS VITALLY IMPORTANT WHERE EITHER PINION IS REPLACED TO FIT THE NEW MATING PINION AT THE SAME TIME. This means that 061057 and 061058 must always be fitted as a pair to ensure correct mating.

This is a reminder of information issued originally in 1966 by the Norton Matchless Service Department.

September, 1971



motorcycles

## SERVICE RELEASE

CATEGORY OF RELEASE: 4 (as overleaf)

No. N.62

NATURE OF RELEASE: Damage to oil pipe by chafing

MODELS AFFECTED: Commando 1971 (all models)

DISTRIBUTION: Worldwide (Trade only)

PARTS INVOLVED: Oil pipes, 062201 (Feed) 062200 (Return)

EXPLANATION: If contact should occur between the oil feed and return pipes and various cycle parts, there is a possibility of oil loss if the pipes should be rubbed through. To counter this, we are repositioning the pipes and also introducing re-inforced pipes which have a much greater **resistance** to damage. The same oil pipe numbers continue and future spares supplies will be of the later type.

ACTION : Examine the oil pipes carefully for evidence of fouling and reposition as required. The points of foul which should be checked are:

- a) Between the rear fender and the point where the metal oil return pipe enters the flexible pipe behind the oil tank.
- b) At the sharp edge of the machined face where the oil tank strainer union abuts to the rear of the tank.
- c) At the horn. (On later models the oil pipe clip is re-formed to hold the pipes clear of the horn). Should the horn slacken on its mountings, this can result in further fouling. To re-secure the horn, remove the rear fender to gain access. Check that the centre bolt does not bottom in the casting and shorten if necessary before retightening.
- d) At the front of the right frame gusset plate adjacent to the rear engine mounting.
- e) At the front of the battery tray.

If the pipes show signs of wear as a result of fouling, replace with the later re-inforced oil pipe.

September, 1971



motorcycles

## SERVICE RELEASE

CATEGORY OF RELEASE:

(As over-leaf)

4

No. N63

NATURE OF RELEASE:

Exhaust pipe lockrings

MODELS AFFECTED :

All Commando

DISTRIBUTION:

Worldwide (for General Distribution)

PARTS INVOLVED:

Exhaust **lockring** NM18092

EXPLANATION:

In cases where slackening of the exhaust lockrings takes place, retightening may not provide a permanent cure. On new motorcycles now leaving the factory, tab washers part number 062412 and lockrings with shorter threads, part number 062464 are fitted for greater security. These tab washers and lockrings can be applied to earlier motorcycles to good effect. The existing lockrings NM18092, which have longer threads can be used with tab washers but the greater clearance will allow the tab washers to move and perhaps chatter. For this reason the new lockrings are recommended.

The tab washers have 3 tabs, one to locate between the cylinder head fins and two tabs, one of which locates between the **lockring** fins.

ACTION:

Locate the single tab of the tab washer between the cylinder head fins. Fit the exhaust with **lockring** and tighten the **lockring** completely. Run the engine to working temperature and then, using a hammer and suitable drift, tap one of the tabs between the most convenient fins. Unintentional slackening of the lockrings is then impossible.

September 1971



motorcycles

## SERVICE RELEASE

CATEGORY OF RELEASE:

4 (as over-leaf) NO.N64

NATURE OF RELEASE:

Heat damage to rear wheel **cush** drive.

MODELS AFFECTED:

1971 and later Commando

PARTS AFFECTED:

062074/062075 Cush drive buffers

DISTRIBUTION:

Worldwide (for General Distribution)

EXPLANATION:

If the rear brake is adjusted incorrectly so that it binds, considerable heat will be generated. It is important to note that the polyurethane **cush** drive buffers will suffer permanent damage if subjected to excessive heat.

A secondary **cause** of **excess** heat in this area is a lack of lubrication at the brake drum bearing.

ACTION:

Take particular care **in** brake adjustment and bearing lubrication. Whenever the rear wheel is removed, check the condition of the **cush** drive buffers and renew if necessary.

SEPTEMBER 1971





motorcycles

## SERVICE RELEASE

CATEGORY OF RELEASE: 4 (as overleaf) NO. N65

NATURE OF RELEASE: Security of rear brake drum bearing circlip.

MODELS AFFECTED: Commando 1971 - all models.

PARTS AFFECTED: **062090 Circlip**

DISTRIBUTION: Worldwide (Trade only)

EXPLANATION: A circlip is fitted between the rear brake drum bearing and the felt seal inner retaining washer. The purpose of the circlip is to retain the bearing in the drum and at all times it must be bedded well into the circlip groove.

ACTION: Whenever the rear brake drum bearing is re-greased as in Service Release N32, the condition and security of the circlip must be checked.

SEPTEMBER 1971



motorcycles

## SERVICE RELEASE

CATEGORY OF RELEASE: (as overleaf)

No. N66

3

NATURE OF RELEASE: Inlet valve guides

MODELS AFFECTED: Commando - all years and models

DISTRIBUTION: Worldwide (Trade only)

EXPLANATION: Following Service Release N45 supplies of new type inlet valve guides and seals were despatched from the Spares Department. The guides despatched were in fact to a special service-fix oversize of -.002 in. The part number of these special valve guides is 062760. The point must be made that this special size guide will not be perpetuated and we are unable to meet orders received on this number. **The** new tupe inlet valve guides are available only against the part numbers and over-sizes listed below:

062725	Standard Size
062767	-.005in oversize
062768	-.010in oversize
062769	-.015in oversize

ACTION: Ensure that future spares orders specify the part number of inlet guides required only from the list above. The part number of the seals to suit these guides is 062726.

September 1971



motorcycles

## SERVICE RELEASE

CATEGORY OF RELEASE: 4 (as overleaf) No. N67

NATURE OF RELEASE: Rear hub disc protective coating.

MODELS AFFECTED: 1971 and later Commando

PARTS AFFECTED: 062082 Rear hub disc.

DISTRIBUTION: Worldwide - for General Distribution.

EXPLANATION: We gather that quite a number of owners and dealers are not aware that the rear hub disc is covered with a clear polythene coating for protection purposes at the storage and assembly stages. There is no problem in retaining the covering excepting appearance. Unfortunately, dirt can become trapped between the disc and protective covering giving an untidy appearance. The covering is easily removed as described below.

ACTION: Carefully wash the centre of the disc by the speedometer drive with petrol. The covering will then tend to lift and can be removed without damage by blowing with an air line at this point and peeling away the pieces.

October 1971



motorcycles

## SERVICE RELEASE

CATEGORY OF RELEASE: 4 (as over-leaf) NO.68

NATURE OF RELEASE: Revised main bearings

MODELS AFFECTED: All years and models of Commando.

DISTRIBUTION: Worldwide (General)

EXPLANATION: We are introducing a new roller main bearing arrangement in production almost immediately. The fitting of this bearing arrangement reduces overall width between the main bearings and increases timing side main bearing journal diameter.

For service purposes we shall in future supply only the crankshaft of the latest production size, part number 063106. To fit this to any Commando engine, the main bearings, part number 063114, must be used in conjunction. The new bearings are 2 dot single lip roller bearings and should be assembled with the lip into the crankcase in both cases.

Main bearing 063114 is of the RANSOMES type MRJ A.30. Alternative bearings which may be used are listed below.

<u>MAKER</u>	<u>TYPE</u>
S.K.F.	NJ306 or NJ306E
F.A.G.	NJ306
N.T.N.	NJ306
Hoffman	R306L
R.H.P.	NF306

All bearings to be 2 dot or C2.

Note in fitting that NJ type bearings have the rollers and cage assembled to the outer race so that the outer **can** be pressed into the crankcase either way **round**. The inner race must be **pressed** onto the crankshaft with the lip leading.

The NF type bearings have the rollers and cage assembled to the inner race. The outer race must be pressed into the heated crankcase with the lip leading. The inner race complete with cage and rollers can be pressed either **way** round onto the crankshaft.

Cont'd.../

The later **crankshaft** of reduced overall width is identified by the letter 'R' stamped onto the timing side crankshaft cheek adjacent to the bearing location. The designed crankshaft **fitted** end float for the new arrangement is **0.010in.** to **0.024in.** (**0.254mm** to **0.6096mm**).

Alternative bearing types are illustrated below:

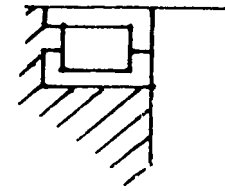
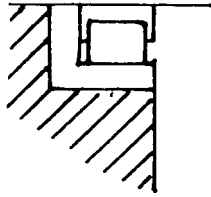
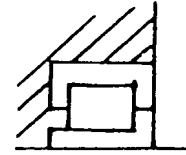
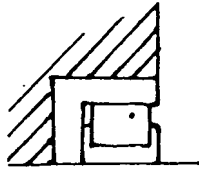

**NF**

**NJ**

OCTOBER 1971



motorcycles

## SERVICE RELEASE

CATEGORY OF RELEASE: 44 (as overleaf) No. N69

NATURE OF RELEASE: Summary of oil consumption causes.

MODELS AFFECTED: A1 1 Commando

DISTRIBUTION: Worldwide (Trade only)

EXPLANATION : From previous experience it is apparent that excessive oil consumption has been caused not by any one deficiency but by the cumulative effect of a number of problems - some extremely basic but some of a minor nature. These problems fall into two categories - common problems and less likely ones, but nevertheless, problems which are known to have occurred and which should be investigated in any obstinate case.

### FACTORY PRODUCTION CHANGES

We have already introduced onto production those modifications necessary to combat excessive oil consumption figures. The factory improvements with introduction engine numbers are listed below but described in detail in the main text.

Taper Piston Rings (Compression)	Engine No.138973
'S.E.' Oil Control Piston Rings	Engine No.147259
(also on engines 146584 to 147176)	
Breaking in oils	Engine No.149624
Inlet Valve Guide & Stem Sealing	Engine No.149670

### COMMON PROBLEMS

ACTION: The rectification for any Commando showing continual evidence of excessive oil consumption should be dealt with as follows, but at all stages ensure absolute cleanliness of all parts receiving attention:-

#### 1) Taper Piston Rings

On any motorcycle returning an oil consumption figure heavier than 200 miles per pint, replace the middle ring on both pistons with the special ring 06-2262. It is essential to fit these rings correctly with the word 'Top' facing upwards so that proper oil control is gained. This special type of ring is identified by a chamfer on the inner diameter.

Cont'd. .... /

## 2) Scraper Piston Rings

Spring expander type oil control rings have been introduced. The piston bodies are revised to accommodate the spring expander type of ring and for this reason it is not possible to use the later rings on an earlier piston or vice versa. For spares purposes the revised pistons with rings as a pair can be used to advantage on previous Commando models. It is not considered good practice to assemble an engine using one old type and one new type piston. The part numbers of the old and new components are detailed below:

Item	Old	New
Piston Complete L.H.	061185	062459
Piston Complete R.H.	061186	062461
Oil Control Ring	061180	062461

## 3) Inlet Valve Guide Seals

New valve guides 062725 fitted with plastic guide to stem seals 062726 have been introduced for the inlet valves only. The new valve guides are similar to the previous guides except for the provision of a groove above the valve guide collar. The groove is to locate the new oil seal. The latest inlet guides, with seals service previous guides for inlet applications only. Under no circumstances must the seals be fitted to the exhaust valve guides. Where there is obvious wetness in the area of the inlet valve head adjacent to the valve guide, replace the previous inlet valve guides with the latest sealed variety. This necessitates removing the inlet valve, spring, etc. Heat the cylinder head to 90° F. whilst driving out of the old guides with a suitable shouldered drift and fit the new guides in a similar manner securing with Loctite AV grade sealant on the outside diameter. If the valve stems are scored, the valves must also be replaced as scoring will render the seals ineffective. After fitting, the valve seats must be re-cut with 45° cutter and the valves will need to be re-ground to the seats. It is most important for the lip of the seal to locate all round in the groove of the inlet valve guide. If the lip is not located, the seal will ride up and down with the valve stem rather than providing a wiping action to prevent oil passing between the valve and guide.

Cont'd...../

- 3 -

The valve guide to valve stem diametral clearance should be 0.002 in. to 0.004 in. (0.508mm to 0.1016mm) when new. Excessive clearance is evidenced by wet oil on the back of the valve heads and can only be rectified by replacing worn valves and guides. Guides are available in 40.002 in., +0.005in., +0.010 in. and to.015 in. oversize on the outside diameter.

#### Inlet Valve Guides

Standard Part No. 062725 +.010in. Part No. 062768  
+.005 in. " " 062767 +.015in." " 062769

#### POSSIBLE ADDITIONAL CAUSES

##### 4) Oil Level

Ensure that the oil tank is not over-filled. Any passage of oil into the crankcase whilst the motorcycle is parked will reduce the oil tank level.

The tendency is then to add oil to restore the correct level. As the motor is run, excess oil will be returned to the tank, resulting in an excess level, and oil transfer through the air filter to the engine results. When checking the oil level, first run the engine for 3 minutes to clear excess oil remaining in the crankcase, stop the engine and allow the oil in the tank to settle for 2 minutes. Now check the level which should not exceed the 'H' mark or fall below the 'L' mark on the dipstick.

##### 5) Breaking in Oils

As a result of development experience it has been found beneficial to speed up the initial breaking-in process for the engine. The recommended oils provide such a degree of protection that the rubbing surfaces require an extended period to bed satisfactorily. A different grade of oil is used for initial bench testing of new engines. At the 500 mile service it is most essential for the oil tank and crankcase filters to be cleaned out thoroughly during oil changing. Use Castrolite for the initial fill.

##### 6) Lack of Oil Return by Pump

###### Oil Pump

Examine the oil return to the tank to ensure that the scavenge side of the pump is working correctly. Possible faults are air leakage between the pump and crankcase due to distortion or wear on the gears.

Cont'd...../



The pump itself can only be inspected and corrected after removal and stripping as described in the Workshop Manual.

7) Crankcase Breather Pipe

Check that there is no obstruction of the crankcase breather pipe by disconnecting the crankcase end and blowing through.

8) Rocker Box Draining

Check for oil return from the rocker boxes to the crankcase. This can be done by pouring a small quantity of oil into the rocker boxes. If drainage takes place very slowly, suspect blockage of the drain hole in the cylinder head and/or cylinder or a misaligned cylinder head gasket masking the drain hole. Check that the drain hole in the head is not masked by the valve spring seat washer.

The cam followers should have a 1/8 in. (3.1750mm) x 45° chamfer on the leading edges to allow oil from the exhaust rocker boxes to drain back to the crankcase between the cam followers. Check that the followers are chamfered and fitted correctly.

9) Crankcase to Chaincase Oil Seal

If it is suspected that oil is passing from the crankcase to the chaincase, renew the crankcase oil seal, lip inboards.

10) Rear Chain Oiler

Excessive oil loss from the rear chain oiler pipe is caused by oil by-passing the felt in the chain oil pipe restrictor. Renew the felt or fit a clip around the plastic pipe to clamp this onto the felt insert.

11) Piston to Cylinder Tolerances

Examine the bores and pistons to establish that the clearances are not excessive. The new Factory produced components allow for a maximum piston clearance of 0.085mm to 0.110mm (0.0033in. to 0.0043in.) measured at the bottom of each piston skirt. Piston ring gaps should also be checked. The closed ring gaps in new condition measure 0.254mm to 0.483mm (0.010in. to 0.019in.) on the compression rings but 0.254mm to 1.016mm (0.010in. to 0.040in.) is permissible on the special scraper rings.



motorcycles

## SERVICE RELEASE

CATEGORY OF RELEASE:

(as overleaf)

4

No. N70

NATURE OF RELEASE:

Disc Brake preparation

MODELS AFFECTED:

1972 Commando with disc brake

DISTRIBUTION:

Worldwide (Trade only)

EXPLANATION:

Will all concerned note that the hydraulically operated disc brake assembly is filled to the correct level with Norton Lockheed Series 329 Fluid, bled and tested prior to leaving the Factory. Since the system is sealed against fluid leakage, it is packed without being drained and in the majority of cases can be put into service without further attention. However, certain conditions encountered during packing may result in damage or leakage. We therefore recommend checking the fluid level after lifting the bellows seal out of the master cylinder. The correct level is  $\frac{1}{2}$  in. (12.9 mm) from the top of the master cylinder reservoir less lid. Top up if necessary with the recommended fluid.

Test for air having entered the system by applying the brake firmly. Any "sponginess" in feel should be rectified by bleeding as detailed in the Owners Handbook. If however the brake has a positive feel and no trace of sponginess, it requires no attention.

DECEMBER 1971



SERVICE RELEASE

No. N71

4

NATURE OF RELEASE: Introduction of battery breather tube.

MODELS AFFECTED: All Commando excepting Interpol.

PARTS AFFECTED: Battery breather tube.

DISTRIEUTION: Worldwide (Trade only).

EXPLANATION: A flexible battery breather tube is introduced against part number **063227** on the recommendation of the battery manufacturers, to carry acid fumes safely-away from painted and plated parts. The battery breather pipe can be fitted to advantage to earlier motorcycles not so equipped.

ACTION: To fit the breather pipe, ensure that the battery is fitted, terminals inboard in the carrier. If a blanking cap is fitted over the breather stub, (in the centre of the blue area of the battery) remove this then fit the flexible breather pipe over the stub. The pipe should be routed over the back of the carrier and to the road forward of the swinging arm pivot.

JULY 1972



---

SERVICE RELEASE

motorcycles

CATEGORY OF RELEASE: 5 (as over-leaf)

No. 72

NATURE OF RELEASE: Interchangeability of exhaust pipes.

MODELS AFFECTED: 1971 Interpol and machines with special low level silencers.

DISTRIBUTION: Worldwide (General).

EXPLANATION: With the introduction of the 1972 Interstate model, an exhaust system has been produced which closely resembles that fitted to Interpol models and is designed to facilitate the fitting of pannier equipment. To commonise on one pair of exhaust pipes and thus facilitate spares supplies we shall in future supply L.H. exhaust pipe 063299 in lieu of 062545, and R.H. exhaust pipe 063240 in lieu of 062546.

ACTION: When attempting to fit a replacement exhaust pipe of the later part number to a 1971 model, abbreviate the inlet end of the silencer by  $\frac{1}{2}$  in. (12.70 mm) and extend the slots to allow the silencer to clamp onto the exhaust pipe. This modification does not affect noise levels.

January 1972



motorcycles

## SERVICE RELEASE

CATEGORY OF RELEASE: 6 (As overleaf) No. N. 73

NATURE OF RELEASE: Exhaust system recommendation.

MODELS AFFECTED: Commando "SS" only.

DISTRIBUTION: Worldwide (Trade only).

EXPLANATION: In service the Roadster exhaust system has been found more satisfactory than the "SS" type. It is therefore advisable, in your best interests, to change "SS" models to the lower level system accordingly. The parts involved in the exchange are as follows:

ITEMS TO DISCARD

000011	Washer	2
2268813	Muffler bolt	4
062383	R.H. Support	1
062384	L.H. Support	1
062385	Support brace	2
062396	Heatshield L.H.	1
062389	Heatshield R.H.	1
062392	Spacer	2
062380	Exhaust R.H.	1
062381	Exhaust L.H.	1

ITEMS TO ADD

060779	Stud	4
061720	Stay muffler	2
060863	Bolt	3
000010	Washer	6
060029	Nut	4
060618	Bolt	2
000012	Washer	2
061722	Guss t	2
060471	Spacer	2
061607	Exhaust R.H.	1
061606	Exhaust L.H.	1

ACTION: In future, where possible, you are requested to order Roadster items when exhaust system replacements are required for "SS" models for any reason.

January 1972



# SERVICE RELEASE

motorcycles

CATEGORY OF RELEASE:

(as overleaf)

4 (See over)

No. N74

NATURE OF RELEASE

Front drum brake - high performance modification.

MODELS AFFECTED

All Commando.

PARTS AFFECTED

Front brake plate and shoes assembly.

DISTRIBUTION

Worldwide (Trade only).

EXPLANATION

To stiffen up the two leading shoe front brake assembly, thereby providing an appreciable improvement in braking figures for high performance purposes, a support plate is introduced. The support plate ties in a precise relationship between both brake cams and pivot pins. The support plate is shown in the illustration, in situ. The parts required to convert an existing brake are available in kit, Part No. 063410, comprising:-

063275	Brake support plate	1
063274	Pivot/Torque stop pin	1
063273	Pivot pin	1
063272	Expander cam	2
26484	Set screw, support plate	2
060395	Tab washer	2

ACTION

To convert an existing brake plate, remove the brake shoes and springs, the brake expander cams and both pivot pins. To remove the short pivot pin, first support the brake plate firmly and squarely under a drilling machine and gently remove the rivetted shoulder of the fixed pivot pin. Final detachment of the stop pin may necessitate heating the brake plate by immersing in boiling water before driving or pressing out. Retain the chamfered washer. Replace the new pivot pin by pressing into the brake plate pin housing and supporting the brake plate and new pivot pin firmly and squarely, fit the washer over the pivot pin, chamfer facing outwards. It is most important to rivet the short pin,

..../....

securely and neatly in position in the brake plate. Replace the second new threaded pivot pin and nut and expander cams. Reassemble the brake shoes and springs then locate the support plate over the brake cams. Secure the plate with set screws 26484 ( $\frac{1}{4}$  in. UNF) and tab washers 060395. Tighten the set screws then tap the tab washers into the position shown in the illustration. The brake is now ready to put back into service.

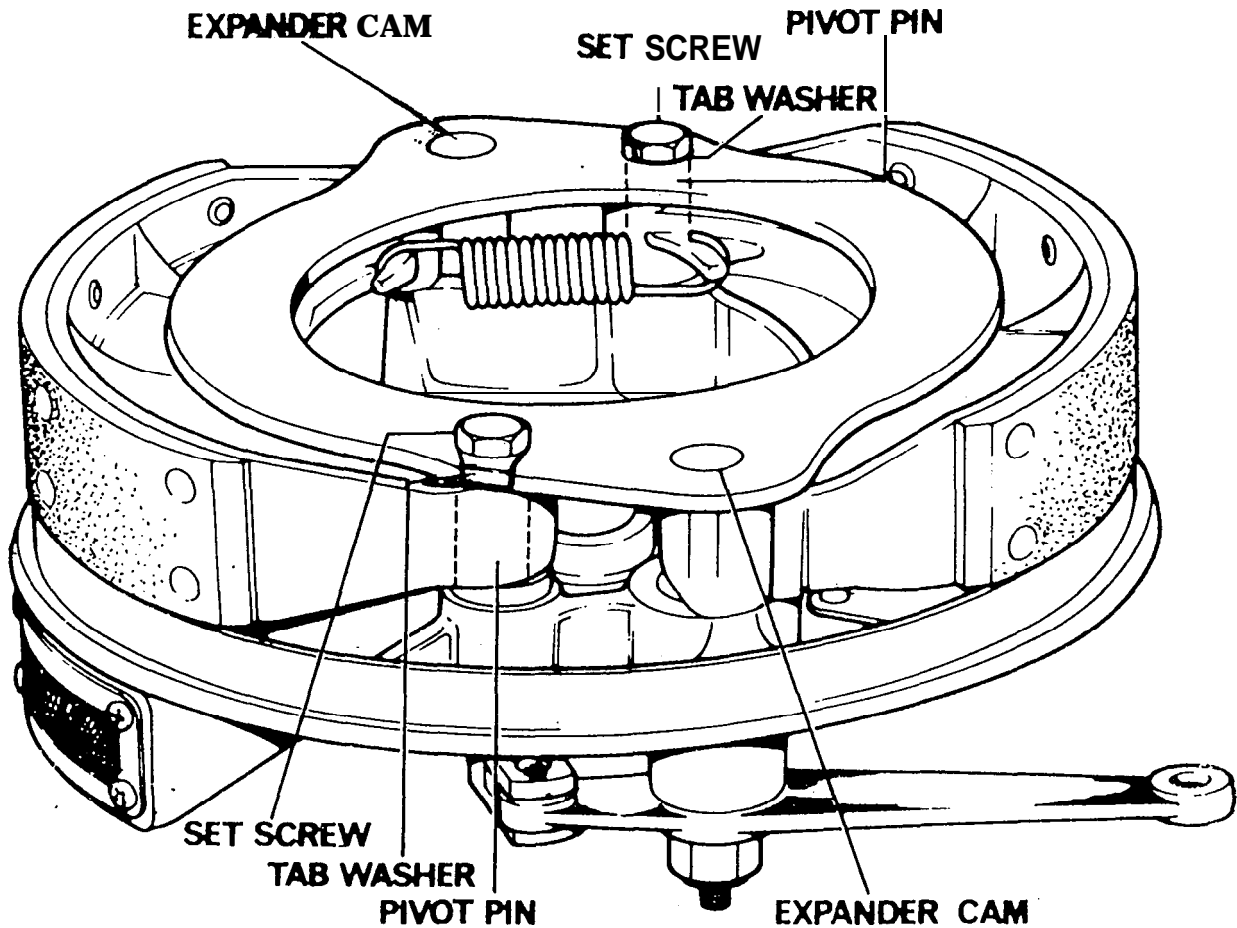



motorcycles

## SERVICE RELEASE

CATEGORY OF RELEASE: 4 (As overleaf) No. N75

NATURE OF RELEASE: Clutch Adjustment.

MODELS AFFECTED: All Commando

DISTRIBUTION: Worldwide (For general distribution)

EXPLANATION: The factory recommendation for adjustment at the clutch pushrod up to the present time has been to screw the adjuster in to give no free movement, then back the adjuster off one quarter turn. Field experience has resulted in the use of two different settings: one quarter turn for motorcycles on which the clutch has bedded down or one whole turn where a new clutch is in use. Further tests reveal no problems from the continued use of the one whole turn setting, rather the reverse. It is for this reason that we have now consolidated on the one whole turn setting which will now be used on production and shown in all new service publications.

ACTION: Adjust all clutches to the new free play setting. To adjust, slacken off as far as possible the cable adjuster at the handlebar control. Remove the large slotted plug on the primary chaincase to gain access to the diaphragm spring centre adjuster locknut. Slacken the locknut and, using a screwdriver, screw the slotted adjuster gently home until contact with the clutch push rod is felt. At this stage, unscrew the adjuster one whole turn. Now, holding the adjuster with a screwdriver to prevent movement, tighten the locknut fully. Clutch pushrod adjustment is now correct and the plug in the chaincase can be refitted. Finally, adjust the clutch cable free play at the handlebar lever to a minimum of 1/8in.(3.2,,)

March 1972.





motorcycles

## SERVICE RELEASE

CATEGORY OF RELEASE: 4 (as overleaf)

No. N76

NATURE OF RELEASE Addition of oil sealing washers

MODELS AFFECTED All Commando

DISTRIBUTION Worldwide (For general distribution).

EXPLANATION In order to improve general oil tightness, we are introducing copper washers, Part No. 063129, beneath the heads of the rocker spindle retaining plate bolts NMT 2256.

ACTION On any motorcycle showing signes of seepage at this point obtain and fit copper washers 063129.

March 1972



motorcycles

**SERVICE RELEASE**

CATEGORY OF RELEASE: 4 (as overleaf) No.N77

NATURE OF RELEASE 1972 Camshafts and bushes

MODELS AFFECTED All Commando

DISTRIBUTION Worldwide (For general distribution)

EXPLANATION New type camshaft bushes with oil groove are introduced for 1972. To suit these, camshafts are being produced without the figure of eight oil groove which was a feature of previous camshafts. Whilst we shall continue to stock the bushes and camshafts of the previous type for spares purposes, all concerned are alerted to the danger of using a 1972 non-grooved camshaft in pre-1972 non-grooved bushes, which would result in oil starvation and possible engine damage. 1972 camshaft bushes are of smaller outside diameter than previous camshaft bushes and as a result, it is not possible to fit later bushes to an earlier crankcase. No harm would result from using a grooved camshaft in a grooved bush if this should prove necessary at anytime,

ACTION : Ensure that the correct years parts are ordered when replacement camshafts or camshaft bushes are required and on fitting recheck that either the camshaft journals or bushes have lubrication grooves.

February 19 72



---

SERVICE RELEASE

motorcycles

CATEGORY OF RELEASE:

4 (as over-leaf) N.78

NATURE OF RELEASE

Frame checking dimensions

MODELS AFFECTED

All Commando

DISTRIBUTION

Worldwide (Trade only)

EXPLANATION

Checking charts have been produced which enable dealers to check any frame which has suffered a severe impact and to check on its suitability for further service. The checking chart for Norton Commando frames is attached.

Those dimensions shown in the end view are most easily checked with the frame **laying** on a surface plate or checking table, supported parallel to the surface **with suitable** blocks or pegs. The dimensions are then measured as the height from the checking surface.

ENCLOSURE

MARCH 1972

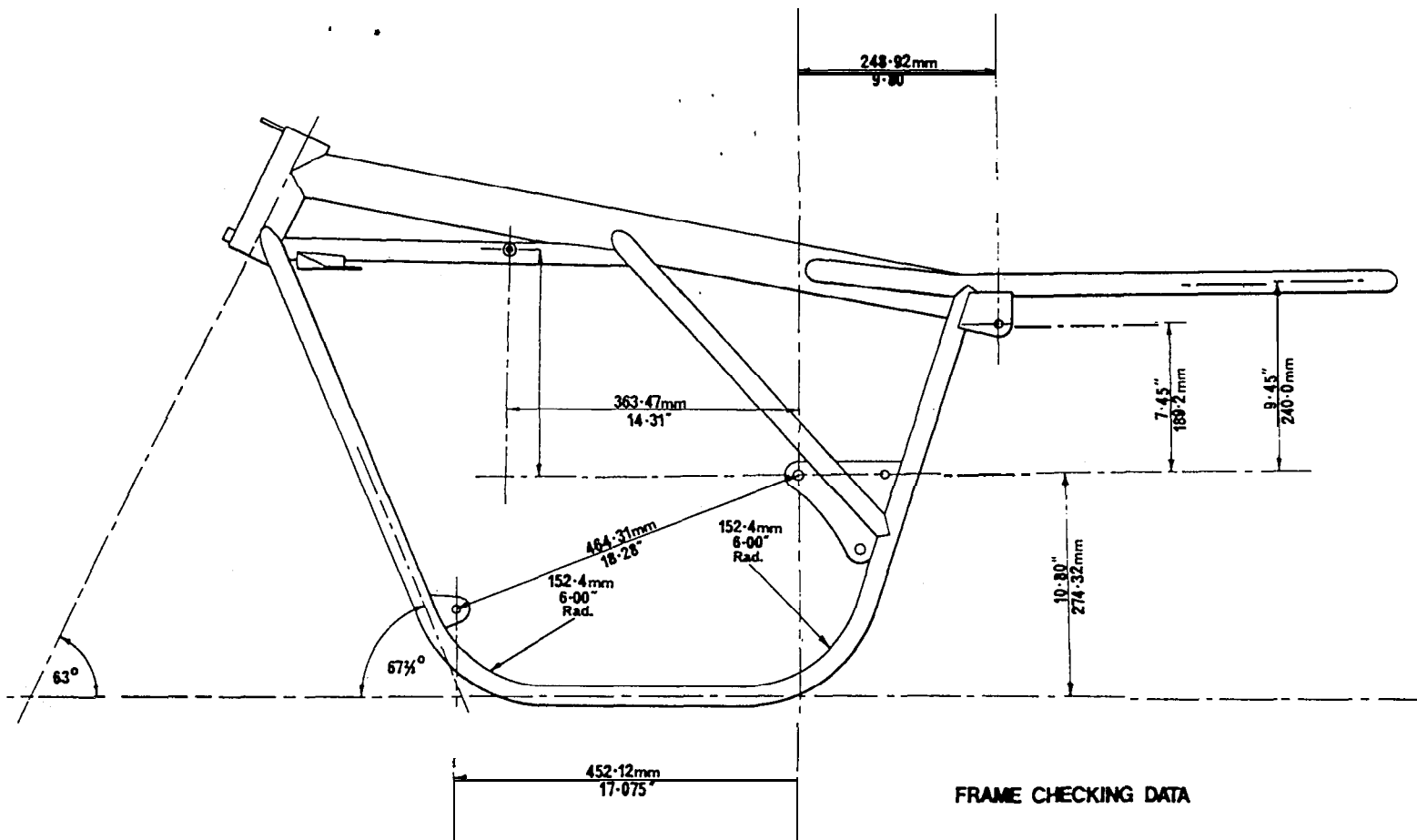

FRAME CHECKING DATA

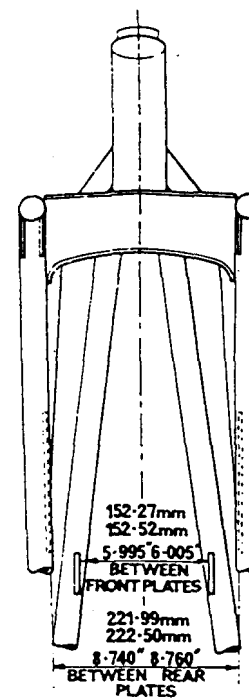

HDP © 1999

HDPQ1999

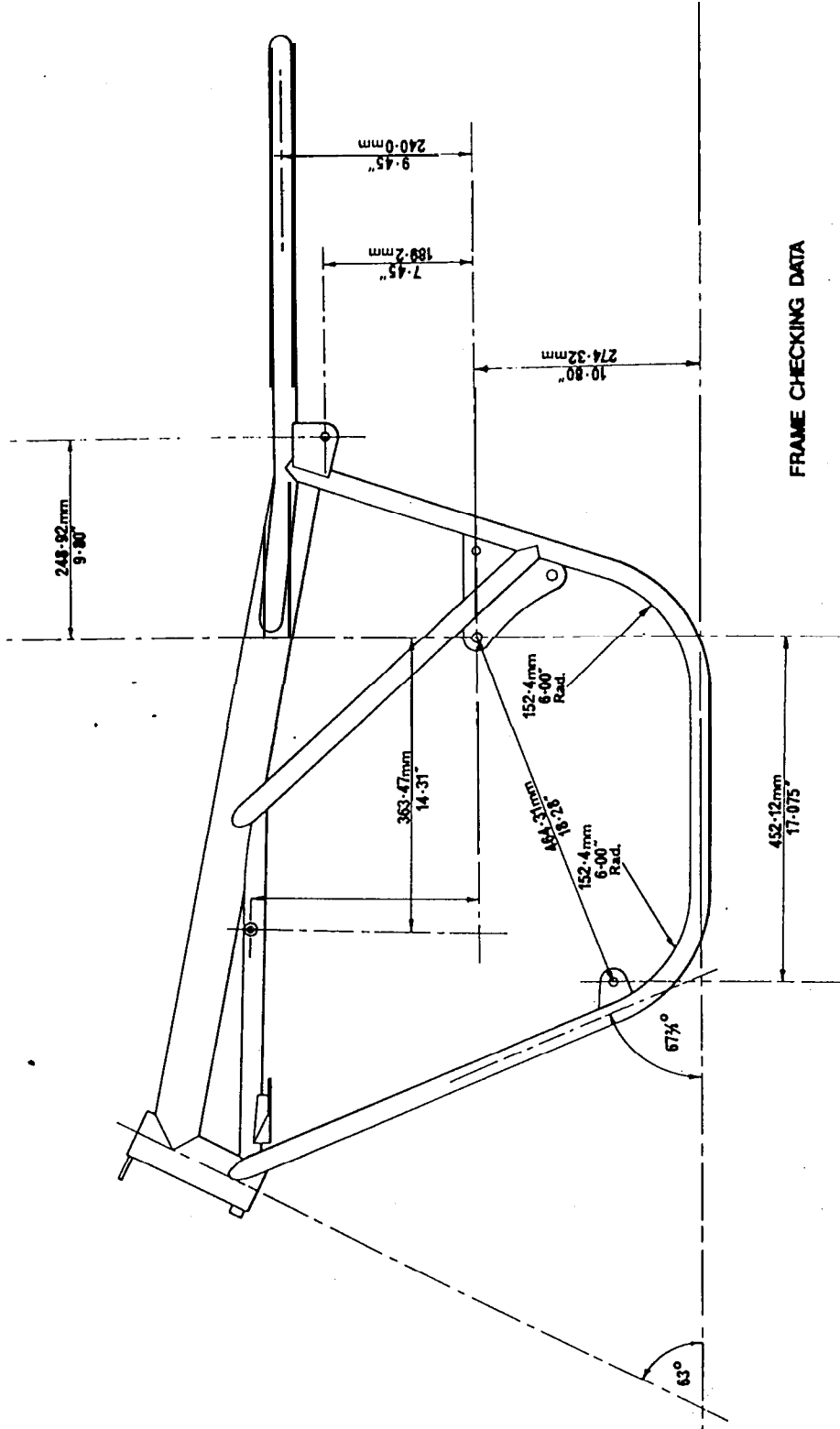
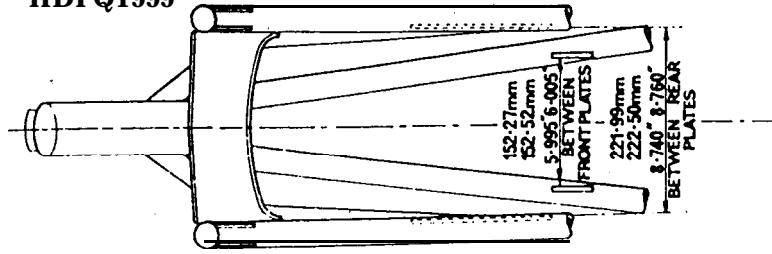



motorcycles

## SERVICE RELEASE

<u>CATEGORY OF RELEASE</u>	4	(as overleaf)	No. N80
<u>NATURE OF RELEASE</u>	Changing oil in front forks.		
<u>MODELS AFFECTED</u>	Commando (all models)		
<u>DISTRIBUTION</u>	Worldwide (Trade only)		
<u>EXPLANATION</u>	<p>Benefit is to be gained from draining and refilling the front forks at the first 500 mile service. This operation has not previously been included in the first free service. At the same time as the oil is changed we advise that the alignment of the fork legs on the wheel spindle be checked. This is a very simple matter and an improvement in fork action can doubtless be gained on some motorcycles.</p>		
<u>ACTION</u>	<p>Using the small drain screw at the bottom side of each fork leg, drain off all lubricant. The large chrome top bolts securing the instrument cases should be slackened and lifted to allow air to enter. To ensure total evacuation of <b>initial</b> fill oil which will have become dirty during early bedding in process, the front brake should be applied and the forks compressed and released several times during drainage.</p> <p>When refilling, refit the drain plugs and sealing washers, measure 150 c.c. (5½ F1.oz.) of SAE20 oil for each fork leg then commence filling. Natural drainage into the fork sliders is a lengthy operation. We therefore recommend pouring in as much of the measured quantity as possible, placing the hand over the top of the fork main tube and compressing and releasing the forks several times. The remaining oil should be added and the process repeated. When the first leg is filled to the correct level, refit and tighten the chrome top bolt and repeat for the other leg.</p> <p>To align the fork legs, merely slacken the spindle pinch bolt on the left leg, bounce the forks several times and retighten. The legs are then aligned correctly.</p>		

February 1972

## SERVICE RELEASE

motorcycles

CATEGORY OF RELEASE:

(as overleaf)

3

No. N.81

NATURE OF RELEASE

Disc brake wheel spokes.

MODELS AFFECTED

1972 Commando with disc brake.

DISTRIBUTION

Worldwide (Trade only)

EXPLANATION

The spoking arrangement of the disc brake type of front wheel requires periodic attention to correct possible loss of spoke tension. To eliminate the need for regular attention, the following technique which is now applied to all disc brake wheels at the factory should be undertaken at the earliest opportunity (prior to delivery where possible):

- 1) With all spokes lightly tensioned, tighten left hand side inboard spokes.
- 2) Tighten left hand side outboard spokes.
- 3) As shown in the illustration below, set the left hand side inboard spokes straight (shaded heavily) by tapping the bowed portion of the spokes with a  $\frac{1}{2}$ lb. (.225Kg) hammer and drift 3" (76.2mm) from the centre of the spoke head.

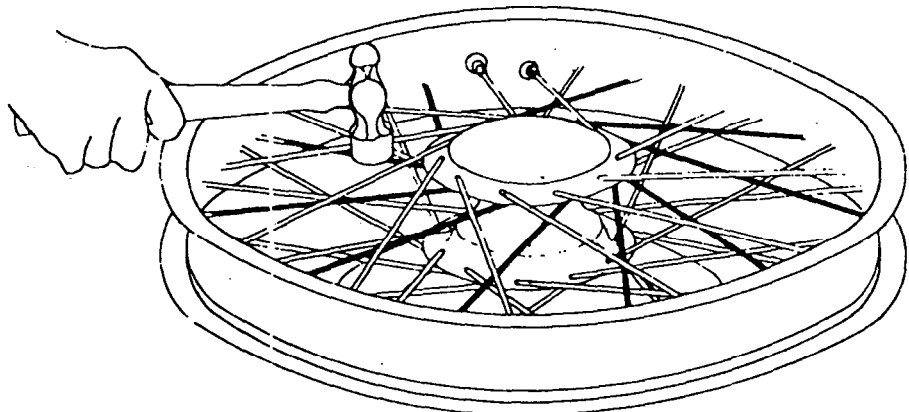

- 4) Retighten the left hand side inboard spokes.
- 5) Tighten the right hand side inboard spokes.
- 6) Tighten the right hand side outboard spokes.
- 7) Recheck wheel for truth and align as necessary.

Realignment of the left side inboard **spokes** as directed will tension the wheels and minimise spoke deflection, making further periodic checking of tension unnecessary.



## SERVICE RELEASE

CATEGORY OF RELEASE: 3 (as overleaf) 1/01

NATURE OF RELEASE: Kickstart foul on right exhaust pipe.

MODELS AFFECTED: 1972 Commando, Interstate and Interpol models only.

PARTS AFFECTED: 063132 Muffler bracket (triangular).

DISTRIBUTION: Distributors only.

EXPLANATION: An alteration has been introduced onto the muffler bracket to provide adequate kickstart pedal operating clearance.

The new bracket, which should only be fitted to the right hand side pipe is **supplied** under part number 063579.

**Alternatively** the existing right hand bracket may be re-formed as indicated below.

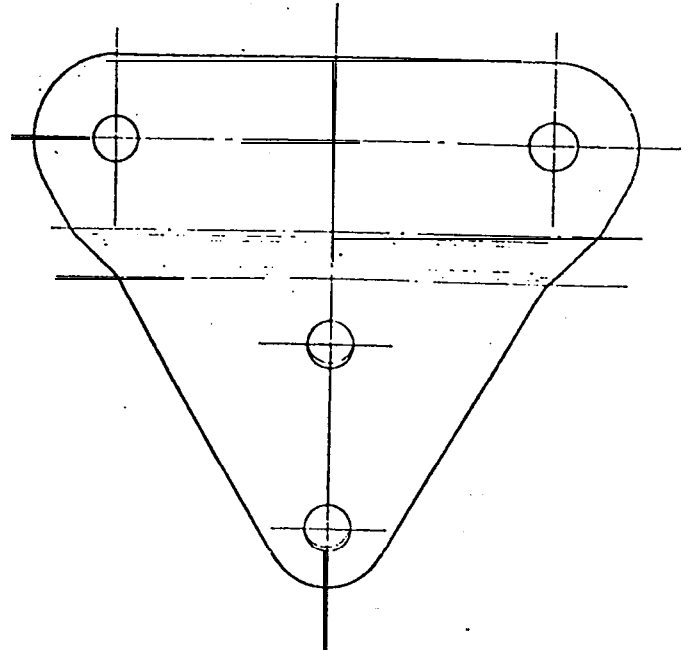
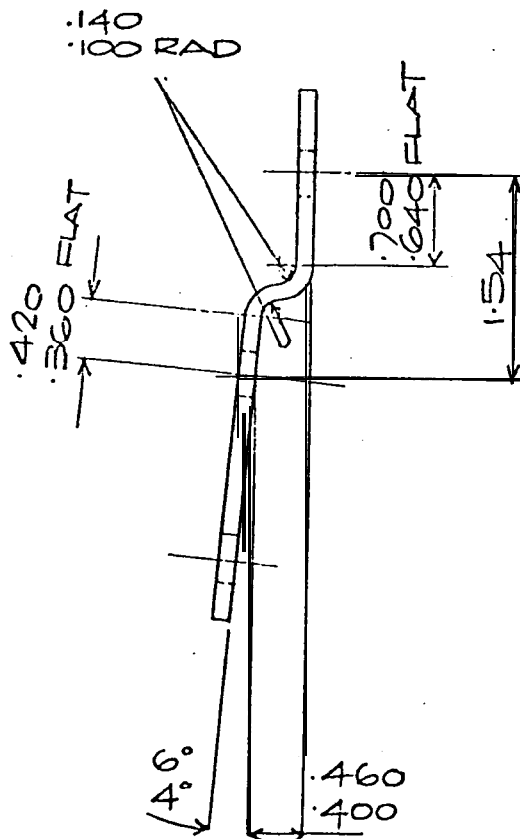

MARCH 1972



motorcycles

SERVICE RELEASE

CATEGORY OF RELEASE:

(as over-leaf)

No. N1/02

5

NATURE OF RELEASE:

Alternative hydraulic hose lengths (disc brake)

MODELS AFFECTED:

1972 and later Commando with disc brake

DISTRIBUTION:

Distributors only

EXPLANATION:

It has been decided to make available alternative lengths of brake hose which can be ordered by distributors and made available at their discretion. Below are listed all the available hydraulic brake hoses with part numbers and lengths:

Standard hose : 062707 Length 25in.

Alternatives : 063508 " 23in.  
063507 " 28in.  
063541 " 31in.  
063540 " 34in.

ACTION:

Where disc braked Commando models are equipped with alternative heights of handlebar, select the most suitable hose length from the list above.

JUNE 1972



SERVICE RELEASE

motorcycles

No. N1/03

NATURE OF RELEASE:

Availability of quartz halogen light units.

MODELS AFFECTED:

All Commando with 7in. headlamps

DISTRIBUTION:

Worldwide (Distributors only)

EXPLANATION:

Quartz halogen light units are now available as a kit through the Spares Department to convert existing headlamp units. The conversion is available only for 7in. diameter headlamps and thus cannot be incorporated on Hi-Rider and "SS" models. The conversion kits available are:

Left hand dip set comprising:

54526114	Light unit
463	Bulb 60/55W
553738	Bulb holder adaptor

Right hand dip set comprising:

54526323	Light unit
472	Bulb 60/55W
553738	Bulb holder adaptor

ACTION:

Where quartz halogen light units are legally acceptable for your market, order the requisite number of conversion kits as normal spares requirements.

JUNE 1972



motorcycles

SERVICE RELEASE

No. N1/04

CATEGORY OF RELEASE:

4 (as over-leaf)

NATURE OF RELEASE:

Reproduction of Service Releases

MODELS AFFECTED:

All Commando

DISTRIBUTION:

Main Distributors only

EXPLANATION:

To avoid production delays a Factory policy decision has been taken that in future main Distributors will be **responsible** for the reproduction and distribution of Service Releases. This will be done from text and, where necessary, artwork supplied from the Factory. The Factory will furnish main distributors with bulk supplies of headed paper to aid reproduction locally.

The reproduction method adopted is left to the distributor's discretion, dependent upon the length of his mailing list. It is most important to retain the **Factory** number sequence.

ACTION:

Advise Technical Department Wolverhampton, & gland, of the quantity of Service Release headings required and periodically call up further quantities as necessary.

JUNE 1972

NORTON WILLIERS CANADA



motorcycles

## SERVICE RELEASE

CATEGORY OF RELEASE:

4 (as overleaf) No. N2/1

NATURE OF RELEASE:

Modification to exhaust valve guides.

MODELS AFFECTED:

All Commando.

DISTRIBUTION:

Worldwide (Distributors and Dealers).

EXPLANATION:

The design of exhaust valve guide NMT2011 has been revised to prevent excessive oil passage between the valves and guides. The upper end of the guide has been shortened so that the taper on the valve stem cannot enter the neck of the guide which would cause a pumping action. To avoid reducing the supporting length of the guide, the lower end of the guide has been lengthened by a similar amount. The modified valve guide is being supplied against part number 063527, and as stocks are exhausted, the later guide will supersede the earlier type directly.

ACTION:

Until dealer stocks of the taller guide are exhausted, ensure where possible that exhaust valve guides are used in pairs.

MAY 1972



motorcycles

## SERVICE RELEASE

CATEGORY OF RELEASE:

4 (as over-leaf) No. N2/2

NATURE OF RELEASE:

Clutch plate oil dispersal grooves.

MODELS AFFECTED:

1972 Commando models.

DISTRIBUTION:

Worldwide (Trade only).

EXPLANATION:

The clutch friction plate 061339 now incorporates scrolled oil dispersal grooves on both sides. The friction plates shown in the Parts List incorporate such grooves but this modification was not in fact effective during the 1971 season. The purpose of the grooves is to disperse oil which can otherwise cause clutch slip. Factory stocks of friction plate 061339 have had the oil dispersal groove added so that future supplies will be to the latest design. It is not necessary to return dealer stocks to the factory but in cases where clutch slip can be attributed to oil on the plates, the modification detailed in Service Release N.5 should be carried out.

APRIL 1972



motorcycles

## SERVICE RELEASE

CATEGORY OF RELEASE:

(AS overleaf)

3

No. N2/3

NATURE OF RELEASE:

Combat valve springs.

MODELS AFFECTED:

1972 Combat engine.

DISTRIBUTION:

Worldwide (Trade only).

EXPLANATION:

On certain Combat engines from the initial production batch, we have become aware of a condition which prevents the valves opening sufficiently.

ACTION:

At the first service or first convenient opportunity, check that the valve springs are not preventing the valves opening fully. With the fuel tank and rocker covers removed, turn the engine until any valve is opened fully, i.e. is depressed into the cylinder as far as permitted by the valve operating gear. At this stage push down the rocker adjuster against the valve stem, such as with an aluminium or wooden shaft, and ensure that the valve can move perceptibly as the spring is depressed further. Repeat this check on all valves in turn. Perceptible movement indicates that all is well but a lack of movement will necessitate the use of a new thinner bottom valve spring cup part number 063396. The thinner bottom cup is identified by the marking "IN" on the inner facing. As an alternative to using new cups, the existing cups NMT2073 may be reduced in thickness to 0.065in.(1.65mm).

The above check applies only to engine number series 200004 to 202340. Thin bottom valve spring cup washers 063396 were fitted from 202341 to 202665. Heat insulating washers NMT3392 and standard cup washers NMT2073 re-introduced from 202666.

APRIL 1972



motorcycles

## SERVICE RELEASE

CATEGORY OF RELEASE: 5 (as over-leaf) No. N2/4

NATURE OF RELEASE: Combat and standard Commando pistons.

MODELS AFFECTED: 1972 Commando.

DISTRIBUTION: Worldwide (Trade only).

EXPLANATION: In order to meet early 1972 production requirements, an interim piston has been produced to accommodate the additional valve lift of the Combat engine, As the new interim Combat pistons differ only from the previous Commando type in the depth of the valve cutaways, the new pistons are therefore currently specified for both standard Commando and Combat versions and supersede the previous pistons **062459** (L.H.) and **062462** (R.H.). When the final Combat pistons become available, they will be of the solid skirt variety and completely interchangeable with the interim Combat pistons (though, ideally, in pairs). The part numbers of the various pistons are detailed below:

COMMANDO PISTONS  
STANDARD AND COMBAT

<u>Piston Type</u>	<u>1971 Models</u>	<u>Interim 1972</u>	<u>Final 1972</u>
	<u>Standard Model Only</u>	<u>Standard &amp; Combat Models</u>	<u>All Models</u>
Standard L.H.	<b>062459</b>	<b>063338</b>	<b>063348</b>
Standard R.H.	<b>062462</b>	063339	063349
+ .010in.L.H.	<b>061187</b>	063340	063350
+ .010in.R.H.	<b>061188</b>	<b>063341</b>	063351
+ .020in.L.H.	<b>061189</b>	<b>063342</b>	063352
+ .020in.R.H.	<b>061190</b>	<b>063343</b>	063353
+ .030in.L.H.	<b>061191</b>	<b>063344</b>	063354
+ .030in.R.H.	<b>061192</b>	<b>063345</b>	063355
+ .040in.L.H.	<b>061193</b>	<b>063346</b>	<b>063356</b>
+ .040in.R.H.	<b>061194</b>	<b>063347</b>	063357

Incoming orders for solid skirt pistons will be fulfilled from interim version stocks until the changeover is completed. Note that on a production basis interim pistons were introduced from engine number 200976 and final Combat pistons from engine number **204166**.

APRIL 1972





motorcycles

## SERVICE RELEASE

CATEGORY OF RELEASE: 5 (as overleaf) No. N2/5

NATURE OF RELEASE: Introduction of disc-brake conversion kit.

MODELS AFFECTED: All Commando years and models.

DISTRIBUTION: Worldwide (Trade only).

EXPLANATION: We have received a considerable number of enquiries for the parts necessary to incorporate the new Norton-Lockheed hydraulically operated disc brake on a Commando previously equipped with the cable operated drum brake. In view of this interest, we have introduced a disc brake conversion kit under part number **063412** which incorporates all the parts needed for this conversion. The kit is offered at a very attractive price and the following list shows the parts incorporated in the kit which is in the form of a cartoned semi-display pack:

<u>Qty.</u>	<u>Part Number</u>	<u>Description</u>
1	061950	Rim and hub assembly c/w bearings
1	<b>062448</b>	Spacer R.H.
1	<b>061885</b>	Disc
5	061960	Stud
5	<b>27815</b>	Nut
5	<b>22528</b>	Washer
	<b>063316</b>	R.H. Slider
1	061926	Caliper assembly complete
2	070029 1	Screw
2	<b>26634</b>	Spring washer
2	063031	Pipe clip
1	<b>062706</b>	Hose support bracket
1	<b>062708</b>	Pipe assembly
1	061938	Master cylinder assembly
1	<b>062707</b>	Hose assembly
1	<b>26634</b>	Washer
1	<b>060347</b>	Nut
4	<b>062241</b>	Screws
1	<b>062524</b>	Cover, stop switch
1	061934	Lucas stop switch
	<b>040606</b>	Copper washer
	<b>0631</b> II	Tin of brake fluid

Dealers will note that the incorporation of the disc brake on a new unsold motorcycle has the twin benefits of increasing saleability and also of releasing for resale the new parts which become displaced during the conversion.

MAY 1972



motorcycles

SERVICE RELEASE

No. N2/6

3

NATURE OF RELEASE:

Crankshaft Main Bearings.

MODELS AFFECTED:

1972 models (commencing engine number 200,004)

DISTRIBUTION:

Worldwide (Trade only)

EXPLANATION:

Field experience with 1972 models (incorporating two single lipped roller main bearings) indicates a small, but significant premature roller main bearing failure rate.

Reported failures have been confined solely to one type of bearing.

ACTION:

When replacing defective roller main bearings, ensure the replacement is a Skefco double lipped outer, single lipped inner spool type NJ306, with a specified nominal internal diametral clearance of 0.0008/0.0012ins. (0.02/0.03mm) prior to fitting (ISO Normal).

Ensure the crankshaft journals are carefully cleaned up, removing all signs of butts or scoring before fitting the inner spool. Models subsequent to Engine Number 207197 incorporate a nominal increase in bearing housing diameter to overcome any significant tendency to excessive closure of the single lipped outer series of roller bearings.

JULY 1972



motorcycles

## SERVICE RELEASE

CATEGORY OF RELEASE: 4 (As overleaf) No. N2/7

NATURE OF RELEASE: Removal of inhibitor coating from new motorcycles.

MODELS AFFECTED: All Commando

DISTRIBUTION: Worldwide (Trade only)

EXPLANATION: All new motorcycles are sprayed with a protective coating after road test and prior to **despatch** from the Factory. The protective coating should be removed before the motorcycle is offered for sale but the choice of solvent must avoid those likely to cause deterioration of any parts, though none of the suitable solvents should be allowed to remain on the tyres.

ACTION : Remove the protective coating by brushing with any hydrocarbon solvent. The following are recommended:

- Petrol (Gasoline) - preferred
- Carbon Tetrachloride
- Trichlorethelene
- Paraffin (Kerosene)

June 1972



## SERVICE RELEASE

N2/08

CATEGORY OF RELEASE: 5

NATURE OF RELEASE: Hydraulic Steering Damper Kit Part Number 064247

MODELS AFFECTED: Commando - All Models

DISTRIBUTION: Worldwide (General Distribution)

EXPLANATION: Resulting directly from racing experience, and in acknowledgement of popular demand, an adjustable hydraulic steering damper kit complete with all attachment brackets, is now available through Norton Villiers Spares channels.

The kit comprises a fully adjustable hydraulic steering damper, part number 064230 and mounting attachments as listed below, and can be fitted to all Commando models.

1	064230	Steering damper
1	<b>054606</b>	Locating bracket
1	<b>064607</b>	Bracket
2	064599	Clamp
1	064611	Stud
4	<b>064608</b>	Bolt
1	061798	Bolt
1	<b>18321</b>	Spring washer
4	<b>25592</b>	Spring washer
4	18315	Plain washer
1	31742/8	Nut
1	26947	Nut
3	<b>062240</b>	Locknut
2	30859	Plain washer
1	064259	Nylon washer
1	<b>062362</b>	Locknut
1	<b>064260</b>	Bolt
1	064256	Spacer

A fully illustrated fitting leaflet, part number 064629, is supplied with each kit, extra copies of which may be obtained for display purposes.

**Note:** The steering damper kit will be found particularly useful in restricting handling problems occasioned by crosswinds, rutted road surfaces, Grooved freeway surfaces, heavy touring luggage etc. It is not intended to rectify maladies in handling occasioned by incorrect maintenance, though an improvement even in these undesirable conditions may well be noted.



## SERVICE RELEASE

No. N.2/9

3

NATURE OF RELEASE: Crankshaft main (roller)bearings

MODELS AFFECTED: 1972 Commando (all models)

DISTRIBUTION: Worldwide (Distributors and Dealers)

EXPLANATION: In order to extend main bearing life, a change of roller main bearing specification has now been authorized, and fitted on production engines from engine number 211891.

The new roller bearing is designated "Superblend" with an increased load carrying capacity and are supplied under part number 063906 (manufacturers part number R & M 6/MRJA30).

ACTION: Where engine units are stripped for examination, or the need for main bearing replacement, fit only **roller main** bearings part number 063906 in place of the previously specified 063114.

The new bearings are fully interchangeable, and should be fitted in pairs for maximum reliability.

Note: The new bearings may also be fitted to advantage to 1971 and earlier Commando machines, provided care is taken fitting the inner spool to the right side crankshaft journal (was 1.1807in. 1.1812in.) diameter, now 1.1812in. 1.1815in. diameter. Also crankshaft fitted end float should be checked, and shimmed where necessary to provide 0.010in. min. 0.020in. max. end float using shim part number NMT2196A as necessary

August 1972



SERVICE RELEASE

No. N2/10

CATEGORY OF RELEASE: 4

NATURE OF RELEASE: Extra high capacity main bearings

MODELS AFFECTED: All Commando

DISTRIBUTION: Worldwide (Trade only)

EXPLANATION: A new main bearing capable of carrying a much higher load than any offered before, has been introduced.

The new bearing, part number **064118**, supersedes the old type **063906** and will be supplied in lieu by our Parts Division. The new bearing should be fitted in pairs.

This bearing may also be fitted to advantage to engines of **1971** and earlier models (originally fitted with a ball bearing as a timing side main bearing).

Ensure that the inner races are firmly seated against the crankcheeks to give a crankshaft end float between 0.010 and 0.024. Any excessive end float can be eliminated by fitting main bearing shims NMT2196A between the outer race and the crankcase.

JANUARY **1973**

**SERVICE RELEASE****mótorcycles**

No. N2/11

CATEGORY OF RELEASE:

2

NATURE OF RELEASE:

Achieving legal noise levels

MODELS AFFECTED:**1973 750** CommandoDISTRIBUTION:

U.S.A./Canada only

EXPLANATION:

All 1973 750 models excepting Hi-Rider have the muffler tail cone mutes supplied separately in the crate in the plastic bag containing the front fender hardware. To meet legal noise requirements for noise limitations in some States it is most essential for the mutes to be fitted before the motorcycle is offered for sale, for otherwise both the selling dealer and new owner may be in violation. The fitting of the mutes necessitates changes to carburetor settings including the fitting of the main jets supplied.

ACTION:

Insert the mutes in the muffler tail cones, lipped end rearwards, align the holes in the mutes and mufflers and fit the self-tapping securing screws securely.

Fit the new main jets by turning off the fuel, removing the carburetor float bowls and holding the main jet holders to prevent turning as the original main jet is removed from the carburetor. Fit the size 220 main jets supplied and refit the float bowls. Remove the carburetor tops, lift out the throttle slides attached to the cables and re-locate the needle clips in the top groove of each needle. Refit the slides and tops.

FEBRUARY 1973



motorcycles

## SERVICE RELEASE

No. N3/1

NATURE OF RELEASE: Tyre pressure recommendation.

MODELS AFFECTED: All 1971/1972 Commando.

DISTRIBUTION: Worldwide (for general distribution)

EXPLANATION: Tyres produced by two different manufacturers are used, in pairs, on Commando models. Due to the different characteristics of the tyre walls, although varying tyre pressures are advantageous under certain circumstances, the front and rear tyre pressures must remain equal for Avon tyres but not for Dunlop. We therefore recommend a minimum tyre pressure of **26 p.s.i.** for Avon tyres front and rear. In the case of Dunlop tyres the following pressures are approved:

	<u>lb/sq.in.</u>	<u>                    </u>
Commando with one 168lb. (76.2Kg) rider :	Front	22      1.547
	Rear	24      1.687
Commando with two 168lb. (76.2Kg) riders :	Front	24      1.687
	Rear	<b>28</b> 1.969
Commando with two 168lb. (76.2Kg) riders	Front	<b>28</b> 1.969
and pannier luggage up to 100lb. (45.36Kg)	Rear	32      2.250

JUNE 1972





motorcycles

SERVICE RELEASE

CATEGORY OF RELEASE: 4 (as overleaf)

No. N3/2

NATURE OF RELEASE: Fuel requirements.

MODELS AFFECTED: Commando (all Models)

DISTRIBUTION: Worldwide (general distribution)

EXPLANATION: The Norton Commando is designed to operate on the following fuels:

Standard Model 97 Octane

Combat model 100 Octane

ACTION: The following alterations will be required to operate on lower grade fuels:

Standard Model 95 Octane 240 Main Jet

Combat Model 97 Octane 250 Main Jet  
26<sup>0</sup> Max.Ign.Adv.

Do not use fuels lower than the alternative ratings and setting given above. A small power loss is to be expected utilising the changes recommended.

May 1972



---

 SERVICE RELEASE

motorcycles

CATEGORY OF RELEASE:

4 (as overleaf)

No. N3/3

NATURE OF RELEASE:

Reversal of handlebar switch clusters.

MODELS AFFECTED:

Late 1972 Commando - all models.

DISTRIBUTION:

Worldwide (for general distribution),

EXPLANATION:

As a direct result of user requests for **right** hand operation of the direction indicators, the decision has been taken to interchange the left and right hand switch clusters. To save changing wiring colour identification at 6 connectors, the functions of kill button and headlamp flasher and spare button and horn shown in Illustration 2 of the Riders Manual are also reversed. New prints of the handbook will include this modified layout but where motorcycles have been **despatched** which are at variance to the handbook, the supplying dealer is requested to acquaint the new owner with the revised layout. From the time of the changeover, the revised control positions will be:

LEFT HAND

Top button - Headlamp flasher  
 Lever switch - Dipswitch  
 Bottom button - Horn

RIGHT HAND

Spare button  
 Direction indicators  
 Kill button

ACTION:

**Ensure** that all new owners of modified models are suitably briefed.

MAY 1972



motorcycles

SERVICE RELEASE

CATEGORY OF RELEASE:

(as overleaf)

4

No. N3/4

NATURE OF RELEASE:

Method of issuing Service Releases.

MODELS AFFECTED:

All Commando models.

DISTRIBUTION:

Worldwide (for general distribution).

EXPLANATION:

To improve continuity in the issue of Service Releases, we shall from now on issue releases in the 4 separate sequences dependent upon destination. The sequences are:

SERIES 1 Distributors only

SERIES 2 Agents and distributors

SERIES 3 General distribution

SERIES 4 One market only

The Service Releases will then bear the number, e.g. 'N' (indicating Norton) 2 (Agents/distributors) followed by the sequential number

viz No. N2/49

The change in method of issue means that each source will from now on be able to maintain a complete file in ascending number order without missing numbers as previously has been the case.

MAY 1972



motorcycles

## SERVICE RELEASE

CATEGORY OF RELEASE: (as overleaf) 5 No. N3/5

NATURE OF RELEASE: Availability of service wallcharts.

MODELS AFFECTED: Commando

DISTRIBUTION: Worldwide (for general distribution).

EXPLANATION: Two colour service wallcharts are now available through normal spares channels showing major assemblies in exploded form, and including data or descriptive panels where appropriate. These charts are not only extremely instructive but are decoratively designed to form an attractive display background for dealers' workshops and showrooms. The charts can be made available in sets for retail sale to the Norton owner and customer. From time to time as important changes take place or factory stocks are depleted, new wallcharts will be introduced. The series 1 charts currently available are as listed below:

**063164** Commando engine (in Blue/Black)

**063165** Commando gearbox (in Bronze Green/Black)

**063166** Commando forks (in Tangerine/Black)

**063167** Commando Isolastic mountings (in Orange/Black)

ACTION: Orders should be placed through normal spares channels, the price being shown in the literature section of the master price list. Supply will only be in sets of four as above.

MAY 1972



motorcycles

---

## SERVICE RELEASE

CATEGORY OF RELEASE:

(as overleaf)

No. N3/6

NATURE OF RELEASE:

Retention of shock absorber segments.

MODELS AFFECTED:

1971/1972 Commando - all models.

DISTRIBUTION:

Worldwide (for general distribution).

EXPLANATION:

It is frequently found difficult to hold the **cush** drive buffers 062074 and 062075 in place in the rear wheel hub whilst the wheel is being fitted to the brake drum in situ.

ACTION:

Use an impact adhesive to **retain** the buffers in the hub and thus facilitate "blind" reassembly of the wheel to the brake drum. Note that the flat side of each **cush** drive buffer abuts to the brake drum paddle and the thick buffers bear the weight of the drive.

MAY 1972



motorcycles

SERVICE RELEASE

CATEGORY OF RELEASE:

(as over-leaf)

4

No. N3/7

NATURE OF RELEASE:

Interchangeability of prop stands.

MODELS AFFECTED:

1971/1972 Commando, all models.

DISTRIBUTION:

Worldwide (for general distribution).

EXPLANATION:

There have been three different prop stands used on 1971 and 1972 models. Each of these can be serviced by the latest production prop stand 063389 using an extra spacer where necessary. The latest stand is equipped with a rubber bump stop (063324) to provide more silent return on the 1972 model. The old and new part numbers are quoted below:-

<u>Old Part No.</u>	<u>New Part No.</u>	<u>Extra Parts Req'd.</u>
<b>063087</b>	<b>063389</b>	
<b>062001</b>	<b>063389</b>	<b>063105</b>

ACTION:

When ordering a replacement stand for **063087** request part number **063389**. When ordering a replacement for **062001** request part number 063389 and spacer 063105 (for the pivot bolt).

# Norton

motorcycles

## SERVICE RELEASE

<u>CATEGORY OF RELEASE:</u>	4	(as over-leaf)	No. N3/8
<u>NATURE OF RELEASE:</u>	Water in front brake..		
<u>MODELS AFFECTED:</u>	1971 and 1972 Commando with drum front brake.		
<u>DISTRIBUTION:</u>	Worldwide (for general distribution).		
<u>EXPLANATION:</u>	<p>During 1971, drain holes were incorporated in the brake drum, breaking through the casting between the first and second fin from the drive (left) side to eject water entering the drum. From time to time the drain holes should be cleared, after removal of the brake cover plate, by the use of a suitable piece of wire or a jet of compressed air.</p> <p>A further improvement in water drainage can be achieved by a simple modification to the brake cover plate by the modification shown below.'</p>		
<u>ACTION:</u>	<p>Check that the drum drain holes are clear, then proceed to modify the brake plate by removal of a small section at the bottom of the anchor plate as illustrated. It is important to radius the corners of the new water exit slot.</p>		

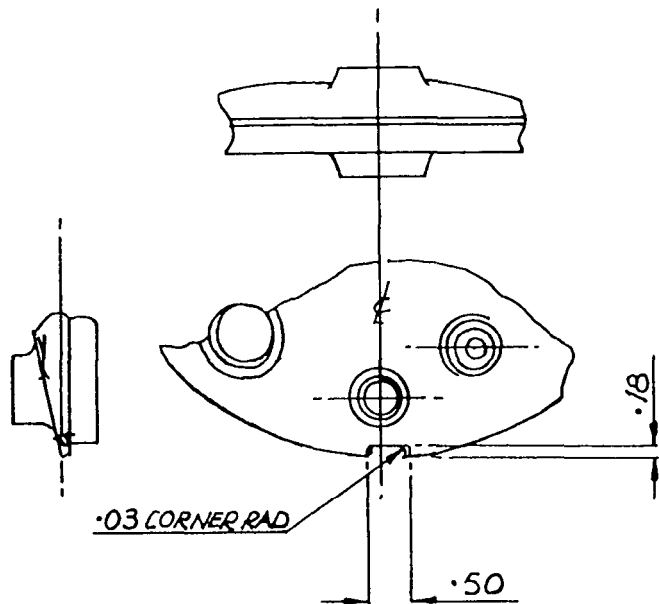

APRIL 1972



motorcycles

## SERVICE RELEASE

CATEGORY OF RELEASE:

(as over-leaf)

4 (see over>

No. N3/9

NATURE OF RELEASE:

Instruction to riders.

MODELS AFFECTED:

All Commando.

DISTRIBUTION:

Worldwide (General distribution).

EXPLANATION:

There is a growing tendency for our customers to neglect turning off the gasoline (petrol) supply when the motorcycle is parked. Whilst the carburetor float needles control the fuel level during normal operation the manufacturers do not guarantee that the needle valve seat pressure is sufficient to prevent fuel passing through the carburetors whilst the motorcycle is parked. This results in neat petrol draining into the engine and joining the lubricant causing both a potentially dangerous situation and inevitable engine damage due to dilution of the lubricant.

ACTION:

Instruct each owner to turn off the gas (petrol) taps whenever the motorcycle is parked. This instruction will be included in all future editions of the Rider's Manual.

MAY 1972





## SERVICE RELEASE

motorcycles

CATEGORY OF RELEASE:

(as over-leaf)

4

No. N3/10

NATURE OF RELEASE:

Isolastic mounting shimming.

MODELS AFFECTED:

All Commando

DISTRIBUTION:

Worldwide (general distribution).

EXPLANATION:

Service Release N.11 of June 1970 laid down a method of shimming Isolastic engine mountings. The method recommended produces satisfactory results but due to varying techniques worldwide, one particular method of shimming has been tested widely and has been approved by the Factory Engineering and Development departments. This will now become the sole method used by all Factory service personnel and, by all concerned with assembly and servicing of the Commando. During shimming, support pre-1971 models on the centre stand but 1971 and later models on a strong box placed beneath the main frame tubes, to relieve tension on the mountings. The recommended ideal clearance from this time, both front and rear, is 0.010in. Shims are available in thicknesses of .005in., .010in., .020in., .030in. Where possible, avoid the use of the thinnest shims which tend to disintegrate after prolonged use, but where proven to be absolutely essential - ALWAYS ENSURE the thinner shims are fitted first onto the tube cap, the thicker shims bearing the load against the mounting tube end. Check the mounting clearance and record the figure prior to re-shimming. Also, it is advisable to renew the polyurethane washers on both sides of each mounting to maintain enginesymmetry, whenever re-shimming proves to be necessary after the first 10,000 miles.

ACTION:

Check existing shimming as follows:

Front mounting - Slide left side gaiter back to give access to the shims and polyurethane washer. Insert feeler gauges as required between the tube cap and polyurethane washer and record the clearance.

Rear mounting - Slide the right side gaiter back to give access to the tube cap and polyurethane washer and record the clearance. Having established that re-shimming is necessary, proceed as below:-

. .... / . ....

Shimming front mounting - Remove the self-locking nut and plain washer from the mounting bolt. Align the flats on the hexagon of the mounting bolt with the timing case casting of the engine. Using a soft metal drift to avoid damaging the threads drive the bolt through sufficiently that the gaiter, collar and polyurethane washer can be removed together.

Remove the tube end cap. If at the time of checking, the clearance was found to be, for example, 0.030in., then a shim of 0.020in. thickness should be added to fit between the end cap counterbore and the end of the-engine mounting tube. Prior to reassembly, clean all the parts including inside the gaiters, and grease lightly using silicone grease RELEASIL No.7. Examine the polyurethane washer for excessive wear producing uneven thickness and replace if necessary. Reassemble the gaiter, mounting collar and polyurethane washer after attention. Note that the reassembly procedure is a reversal of that used in dismantling but take care to fit the end cap with shims snugly over the actual mounting to allow room for the gaiter, spacing washer and polyurethane washer to be fitted together, Secure the mounting bolt and nut to a torque reading of 25lb./ft.

Shimming rear mounting - Remove the self-locking nut and washer from the right end of the main mounting stud. Using a soft metal drift drive the mounting stud **partially** through, right to left until it protrudes some 4in. from the left hand side. Slide the right gaiter lip off the mounting tube then push down and rearwards clear of the frame the gaiter, mounting collar and polyurethane washer as a group. Collect the right side tube cap complete with shims.

As with the front mounting, the thickness of shims required should be determined from the measurement at the time of checking against the designed clearance. For example, to correct a clearance of 0.030in., a single 0.002in. shim would need to be added. Reassemble as follows:

Clean and grease lightly the parts of the right tube cap/gaiter group using silicone grease RELEASIL No.7. Examine the polyurethane washer for excessive wear producing uneven thickness and replace if necessary. Fit the shims into the tube cap counter bore and reassemble to the mounting with the thickest shim to the cap.

In order to refit the gaiter, polyurethane washer and mounting collar, the gaiter must be held back as far as possible on the lip of the collar to gain sufficient room for fitting. If it proves extremely difficult to insert the parts, have a second operator push the rear wheel as far as possible from right to left, thus providing maximum clearance at the end of the rear mounting.

...../.....

After entering the end cap, gaiter, etc., ensure that the gaiter fits completely over the mounting and cap without being trapped at either end. Check then that the collar, polyurethane washer, etc. are free to revolve with the gaiter. Using a soft metal drift, tap the main mounting stud right **through** from the left side and have the assistance of a second operator to align the frame lug with the mounting bolt, levering if necessary between the engine plate and frame tube to aid **alignment, and** inserting the spacer between the alloy footrest mounting plate and frame bracket. Fit the plain washer and self-locking nut and tighten to a torque of **25lbs.ft.**

Finally, check that both gaiter/end cap assemblies can be revolved by finger pressure. If not, recheck to ensure that the gaiters have not been trapped.



motorcycles

## SERVICE RELEASE

CATEGORY OF RELEASE: 3 (as overleaf)

No. N3/11

NATURE OF RELEASE: Silencer Mute

MODELS AFFECTED: All Commando

DISTRIBUTION: Worldwide (for general distribution)

EXPLANATION: In order to improve the acceleration characteristics of 1972 Commando models fitted with Combat engines, where silencing mutes have been fitted to the mufflers, a new mute has now been introduced under the following part number: -

063763 Mute

063763 mute is identical to the previous 061984 mute, apart from the outlet bore size, which has been increased from 3/4 in. (19 .0mm) diameter, to 1 in. (25.4mm)

It is permissible to amend existing stocks. The new outlet diameter bore mutes should only be fitted in pairs. Carburation and effective noise levels are not affected.

June 1972



motorcycles

## SERVICE RELEASE

CATEGORY OF RELEASE:

(As overleaf)

No. N3/13

NATURE OF RELEASE

Camshaft interchangeability (read in conjunction with Service Release N.77)

MODELS AFFECTED

1970 and 1971 Commando (all models)

PARTS AFFECTED

Camshaft/Crankcase/Cylinder heads and valves

DISTRIBUTION

Worldwide (for general distribution)

EXPLANATION

Following the introduction of new crankcases with modified breathing, together with the introduction of the Combat "SS" type camshaft, there are now several possible combinations of crankcases and camshafts. In addition, where it is desired to fit the high performance "SS" type camshaft to a pre-1972 engine there are problems with cam lobe clearance at the crankcase oil filling shroud. In addition problems can arise due to valve head diameter, valve stem and spring length discrepancies particularly where an early "non-Combat" cylinder head is fitted.

It is also essential to fit tappet locating plates 063092 to accommodate the increased lift on both "SS" and "SSS" camshafts.

The part numbers and applications of the various components are tabled **below:-**

<u>Cam Part Number</u>	<u>Identification Stamped on</u>	<u>Journal Type</u>	<u>Use Part Number</u>	<u>Comments</u>
061084	S	Scrolled	061084	Standard 1971 plain bushes
062608	S	Plain	061084	Standard 1972 scrolled bushes
062673	ss	Plain	063536	Combat 1972 scrolled bushes
062807	ss	Scrolled	063536	Combat 1972 plain bushes
<b>063536*</b>	ss	Scrolled	063536	Combat 1972 plain bushes
<b>063537*</b>	ss	Plain	063536	Combat 1972 scrolled bushes
TX0302	sss	Scrolled	063761	+ Original NVPS camshaft, plain bushes
063453	sss	Plain	063761	Variant TX0302, Scrolled bushes
<b>063761*</b>	sss	Scrolled	063761	Variant TX0302, plain bushes

Use scrolled journal camshafts prior to Engine Number 204048 with plain bushes NMT2036 & NMT 2037

Use plain or scrolled journal camshafts subsequent to Engine Number 204049 with scrolled bushes 062600.

NOTE: Scrolled condition camshafts only will be supplied against orders for all above camshafts.

Surface Treatment.

Cont'd...../

- 2 -

3 Conversion from standard cams to Combat condition requires the following:-

- a) Cylinder head 063327 to provide 10:1 compression ratio
  - b) Solid skirt Combat pistons (063348 LH, 063349 RH,Std.)-see Service Release N.2/4 for oversizes
  - c) Combat valves-inlet 063283, exhaust 063282
  - d) Standard valve springs NM22838 **outer**,NM22839 inner using spring seat and spacers to provide 0.050 in. (1.27mm) clearance at full lift.
  - e) Combat tappet locating plates 063092.
- + Conversion to "SSS" specification -as Combat from standard  
-no further action required for Combat

May 1972



motorcycles

SERVICE RELEASE

CATEGORY OF RELEASE:

(as overleaf)

No. N3/14

4

NATURE OF RELEASE:

Revision to Service Release N3/10 (Isolastic Shimming)

DISTRIBUTION:

Worldwide (General distribution)

MODELS AFFECTED:

Commando (all models)

EXPLANATION:

Due to a typographical error reference is made in Service Release N3/10 sheet 2 to the addition of a 0.002in. shim in the rear mounting. This should of course read 0.020in. A new sheet 2 for this release, showing the correct figure, is enclosed.

ACTION:

Substitute the new sheet 2 in your copy of the release and destroy the original.

JUNE 1972

ENCLOSURE

Shimming front mounting - Remove the self-locking nut and plain washer from the mounting bolt. Align the flats on the hexagon of the mounting bolt with the timing case casting of the engine. Using a soft metal drift to avoid damaging the threads drive the bolt through sufficiently that the gaiter, collar and polyurethane washer can be removed together.

Remove the tube end cap. If at the time of checking, the clearance was found to be, for example, 0.030in., then a shim, of 0.020in. thickness should be added to fit between the end cap counterbore and the end of the engine mounting tube. Prior to reassembly, clean all the parts including inside the gaiters, and grease lightly using silicone grease RELEASIL No.7. Examine the polyurethane washer for excessive wear producing uneven thickness and replace if necessary. Reassemble the gaiter, mounting collar and polyurethane washer after attention. Note that the reassembly procedure is a reversal of that used in dismantling but take care to fit the end cap with shims snugly over the actual mounting to allow room for the gaiter, spacing washer and polyurethane washer to be fitted together. Secure the mounting bolt and nut to a torque reading of 25lb./ft.

Shimming rear mounting - Remove the self-locking nut and washer from the right end of the main mounting stud. Using a soft metal drift drive the mounting stud partially through, right to left until it protrudes some 4in. from the left hand side. Slide the right gaiter lip off the mounting tube then push down and rearwards clear of the frame the gaiter, mounting collar and polyurethane washer as a group. Collect the right side tube cap complete with shims.

As with the front mounting, the thickness of shims required should be determined from the measurement at the time of checking against the designed clearance. For example, to correct a clearance of 0.030in., a single 0.020in. shim would need to be added. Reassemble as follows:

Clean and grease lightly the parts of the right tube cap/gaiter group using silicone grease RELEASIL No.7. Examine the polyurethane washer for excessive wear producing uneven thickness and replace if necessary. Fit the shims into the tube cap counter bore and reassemble to the mounting with the thickest shim to the cap.

In order to refit the gaiter, polyurethane washer and mounting collar, the gaiter must be held back as far as possible on the lip of the collar to gain sufficient room for fitting. If it proves extremely difficult to insert the parts, have a second operator push the rear wheel as far as possible from right to left, thus providing maximum clearance at the end of the rear mounting.

...../.....





motorcycles

**SERVICE RELEASE**

No. N3/15

4

NATURE OF RELEASE:

Security of battery in carrier

DISTRIBUTION:

Worldwide (general distribution)

MODELS AFFECTED:

All 1971 and later Commando

EXPLANATION:

If the battery is not secured tightly in the carrier, movement will occur resulting in damage to the battery casing. The battery securing bar to which the battery strap clamps locate has additional slots to provide for the Police twin battery arrangement. With the single standard battery in use, the inboard slots should be used to keep the straps as close as possible to the battery.

ACTION:

Locate the battery strap clamps to the securing bar inboard slots to prevent movement of the battery.

JUNE 1972



motorcycles

## SERVICE RELEASE

No. N3/16

NATURE OF RELEASE: Oil in timing case.

MODELS AFFECTED: 1972 Commando all models

DISTRIBUTION: Worldwide (General Distribution)

EXPLANATION: Since the introduction of the latest crankcases and roller timing side main bearing the initial flow of oil passing into the timing case has diminished, and in consequence when a new or rebuilt 1972 engine is run for the first time, oil must be added from an outside source to prevent the timing gear running dry initially. After the engine has run for some minutes, oil will automatically accumulate in the case to lubricate the timing chain and pinions. Thereafter there is no necessity to add lubricant manually unless the cover is once again removed.

ACTION: Prior to running a 1972 type engine for the first time, or after service work when the timing cover has been removed, pour oil into the inlet rocker box till full, then replace the rocker cover. Oil will then drain gradually through the rocker box drain hole into the timing case, thus providing initial lubrication for the timing gear.

JUNE 1972



motorcycles

**SERVICE RELEASE**

N.3/18

2

NATURE OF RELEASE: Battery location and retention

MODELS AFFECTED: 1971/2 Commando

DISTRIBUTION: Worldwide (for general distribution)

EXPLANATION: In order to eliminate the possibility of battery movement in service, with resulting wiring harness or fuse failure, additional rubber packing has been incorporated onto the battery tray to provide greater battery support. A further protection to the electrical circuit has been provided by the introduction of a rubber buffer onto the rear panel of the oil tank.

ACTION: **When fitting** or replacing the battery ensure five rubber pads are provided:

- 2 off 062602 (was 3 off)
- 2 off 063962 (new)
- 1 off 063961 (new)

Remove the three existing rubber strips part number 062602. Using rubber based impact adhesive, glue two of the 062602 strips to the back face of the battery tray, the uppermost as high as possible. Glue the two new rubber pads 063962 onto the tray base.

Fit the new rubber pad 063961 to the rear face of the oil tank in line with, and at the same level as the battery **terminals**, to eliminate any possibility of mechanical foul or electrical shorting.

Replace the battery with the terminals "inboard", facing towards the centre of the motorcycle, keeping the battery retaining straps (061662) as near vertical as possible. Avoid cleating the crossbar in the two inner 'notches' as this tends to allow the battery to shuffle, resulting in crossbar contact and fouling of the 2MC capacitor.

Fit battery vent pipe and route vertically downwards to direct acid fumes or spillage below the lower frame level of the machine..

AUGUST 1972



**SERVICE RELEASE**

No. N3/19 .

CATEGORY OF RELEASE:

5

NATURE OF RELEASE:

"Majorca" European type low handlebars 064887

MODELS AFFECTED:

All Commando

DISTRIBUTION:

Worldwide (General distribution)

EXPLANATION:

To meet increasing demands for the availability of reduced width "low type" European handlebars, a new handlebar part number **064887** has been made available and can be obtained through the normal parts outlets.

Alternative control cables are necessary when using the new narrow low level "Majorca" handlebars, which have been specifically developed to **accept** the existing disc front brake master cylinder and hydraulic equipment.

ACTION :

Replace existing components as follows:-

- 1 **064887** "European low" handlebar
- 1 **064963** Clutch cable
- 1 **064964** Air cable

MAY 1973



---

 SERVICE RELEASE

No. N.3/20

3

NATURE OF RELEASE: Positive location of engine mounting buffers.

MODELS AFFECTED: Commando (all models)

DISTRIBUTION: Worldwide

EXPLANATION: Mis-location of the front or rear engine mounting buffers (Part No.061278 front, 061280 rear) can affect the location and seating of the power unit in the frame, which will result in a deterioration of handling characteristics.

Mis-location is evidenced by unequal tension and spacing of the top engine steady mounting rubbers, indicating undue stress in the top to engine steady plate.

ACTION: Remove the top engine steady and check the lie of the power unit in the frame. Withdraw the front and rear engine mounting bushes, spacers and buffers in turn, and replace the spacers with the later pattern incorporating circlips and grooves each side of the buffer to locate the rubber buffers positively within both engine mountings.

	Old	New
Front Engine mounting spacer (1 off)	061277	063960
Rear Engine mounting spacer (2 off)	061279	063298
Circlips	063927	

The existing rubber mounting buffers should be refitted, located using the above procedure

Check the top engine steady for symmetrical assembly, with balance tension between the mounting rubbers.

August 1972



## SERVICE RELEASE

motorcycles

N3/21

3

NATURE OF RELEASE:

Cylinder Head Gasket

MODELS 'AFFECTED:All **750 c.c.** Commando modelsDISTRIBUTION:

Worldwide

EXPLANATION:

1. A revised cylinder head gasket, part number **063844**, has now been introduced on all production models from engine number 212173. The new gasket incorporates steel fire ring 'eyelets' which provide a more positive gas seal under arduous conditions. This new gasket is fully interchangeable and should be used as a direct replacement for the earlier cylinder head gasket 060400.
2. An alternative (thicker) copper gasket is now made available through Spares channels under part number **064071** (1mm thick 0.040in. nominal).
3. 064072 (2mm thick) copper gasket is available for markets where a reduction in compression ratio may prove desirable to meet local fuel availability requirements.

Use only H..M.P. grease when assembling either type of cylinder head gasket. Fit the non-metallic type under dry cylinder barrel to head conditions.

Effective Compression Ratios

1972 Combat Commando  
(063327 Cylinder Head)

	<u>Compression Ratios-(Nominal)</u>	
	<u>With Cyl. Base Gasket</u>	<u>W/out Cyl. Base Gasket</u>
Original gasket 060400, (0.030in.)	9.8:1	10:1
Replacement gasket 063844	9.8:1	10:1
1mm Copper Gasket '064071 (0.040in.)	9.5:1	9.8:1
2mm Copper Gasket 064072 (0.080in.)	8.8:1	9:1

Removal of cylinder base gasket NM24249 necessitates the use of an alternative joint sealing compound (e.g. Douglas Kane Loctite "Instant Plastic Gasket").

SEPTEMBER 1972

**NORTON VILLIERS CANADA LIMITED**



SERVICE RELEASE

N.3/22

4

NATURE OF RELEASE: Swinging Arm Pivot Spindle 064077

MODELS AFFECTED: All Commando .

DISTRIBUTION: Worldwide (General Distribution)

EXPLANATION: The above oversized swinging arm pivot spindle has now been made available through normal spares channels, enabling reclamation of rear engine mountings, where excessive spindle bore wear has taken place.

Standard spindle diameter (060453) 0.8740in.(22.200mm)  
0.8745in.(22.212mm)

O/size spindle diameter (064077) 0.8790in.(22.327mm)  
0.8795in.(22.340mm)

ACTION: Use of an expanding reamer is recommended to clean up the worn spindle bore to provide a designed working clearance of 0.0005 - 0.0020in. (0.012 - 0.051mm) with the new oversized spindle.

The swinging arm pivot bearings should be bored to 0.8807 - 0.8817in. (22.370 - 22.395mm) to provide the correct running clearances.

SEPTEMBER 1972



motorcycles

## SERVICE RELEASE

N3/23

3

NATURE OF RELEASE: Cylinder head interchangeability

MODELS AFFECTED: All **750 c.c.** Commando models

DISTRIBUTION: Worldwide

EXPLANATION: Introduction of **the current** 32mm carburetter version of the standard Commando engine unit, replacing the previous 'Combat' specification (w.e.f. engine number 211110) has necessitated the introduction of two new cylinder heads which are listed below.

Interchangeability can be effected as shown, utilising the available range of cylinder head gaskets, in conjunction with the deletion of the cylinder base gasket where indicated.

Cylinder Heads

<u>Part No.</u>	<u>Description</u>	<u>Compression Ratio (Nominal)</u>		<u>Identification</u>
		<u>Using 0.030in. Cyl. Head Gasket</u>	<u>With Cyl. Base W/out Cyl. base Gasket</u>	
060988	Standard Commando 1968/72(30mm)	8.9:1	9.2:1	RH1
063327	Combat 1972 (32mm)	9.7:1	10:1	RH3
<b>064048</b>	Standard Commando 1972/3(32mm)	8.9:1	9.2:1	RH5
064097	Standard Commando 1972/3(32mm)	9.3:1	9.6:1	RH6

Alternative Compression Ratios Available (Using copper gaskets & deleting the cylinder base gasket NM24249)

<u>Cylinder Head</u>	<u>Sphere Depth</u>	<u>With Cyl. Base Gasket</u>		<u>W/out Cyl. Base Gasket</u>	
		<u>064071 (1mm)</u>	<u>064072 (2mm)</u>	<u>064071 (1mm)</u>	<u>064072 (2mm)</u>
060988	Nominal	8.7:1	8.1:1	9:1	8.3:1
063327	<b>-0.040</b>	9.5:1	<b>8.7:1</b>	9.8:1	9:1
064048	Nominal	8.7:1	8.1:1	9:1	8.3:1
*064097	-0.020	9:1	8.5:1	9.4:1	8.6:1

\*064097 is the preferred item for stocking purposes.

Douglas Kane Loctite "Instant Plastic Gasket" is recommended for the cylinder base joint where NM24249 is deleted.

Use H.M.P. grease for both copper cylinder head gasket joints.

SEPTEMBER 1972

NORTON VILLIERS CANADA LIMITED





SERVICE RELEASE

No. N3/25

CATEGORY OF RELEASE: 5  
NATURE OF RELEASE: "Quick action" throttle twistgrip 064600  
MODELS AFFECTED: 1973 Commando from engine number 301700  
DISTRIBUTION: Worldwide (for general distribution)  
EXPLANATION: In order to provide more comfortable throttle action at the handlebar control end, a new "quick action" throttle twistgrip has been introduced pnto general production, with effect from engine number 301700.

ACTION: The new twistgrip will be serviced a6 a complete replacement under assembly part number 064600.

The following individual replacement component parts will also be supplied through normal spares outlets:-

364/012 Twistgrip rotor  
11/013 Body half clamp screws

The earlier standard and the new "quick action" throttle twistgrips will continue to be serviced.

MAY 1973

## SERVICE RELEASE

N3/26

CATEGORY OF RELEASE: 4

NATURE OF RELEASE: Pannier and Luggage equipment

MODELS AFFECTED: Commando (all models)

DISTRIBUTION: General Distribution (Worldwide)

EXPLANATION: Attention is drawn to the damage that can be caused to a machine if luggage carrying equipment is not suitable for the motorcycle, or not fitted correctly.

Two major problems that can arise are:-

- a> Overloading an unsupported rear frame loop
- b) Fracturing of rear suspension units caused by carrier frames bearing on damper top spring collars.

ACTION: Only fit pannier equipment or rear carriers that are strongly and stiffly braced from both left and right support plates to a point approximately 12 inches (30cm minimum) rearwards from the dual seat knurled fixing nut. Unless the carrier frame is adequately braced, overload and distortion of the rear frame loop will inevitably occur.

Ensure the carrier frame loop that locates forward onto the suspension unit top bolt lies completely clear and free of the top fixing eye, and/or the top spring collar.

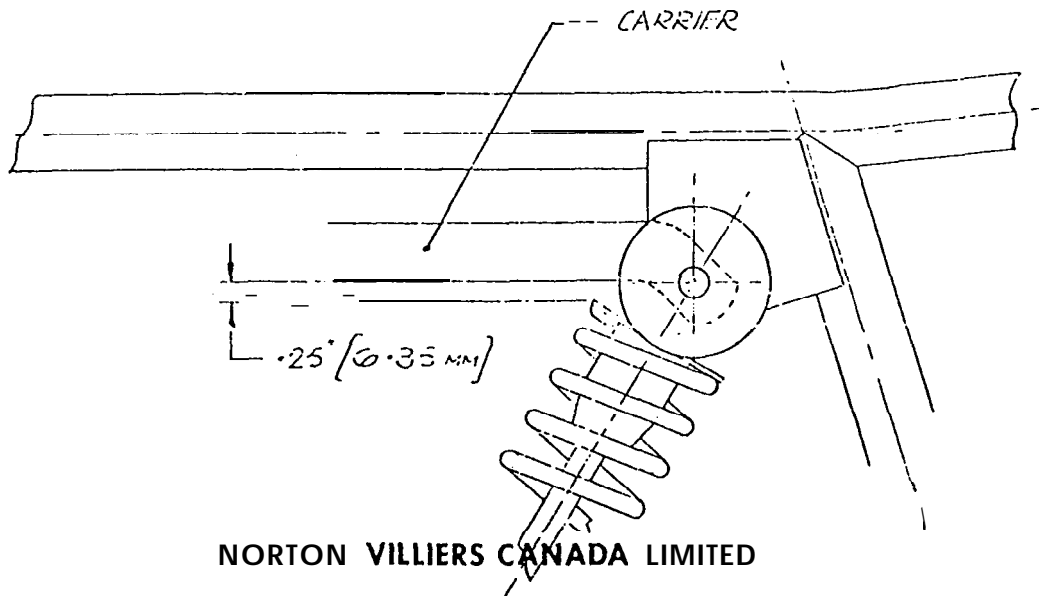

Any contact or loading at this point nullifies the fully floating effect of the bonded ferrule and bush assembly on the damper unit, and applies assymetric thrust onto the unit itself. In extreme cases the fixing eye can be torn off the damper body.

Remember the bushes are further compressed with rider and passenger weight on the machine, whilst loading the pannier/carrier equipment may further reduce the available clearances. The minimum static clearance as illustrated should be .25in. (6.35mm).

Riders fitting pannier and luggage equipment must appreciate that mounting excessive baggage too high or too far rearward is likely to adversely affect the handling characteristics of the machine..



## SERVICE RELEASE

N. 3/27

CATEGORY OF RELEASE: 4

NATURE OF RELEASE: Introduction of 'Veglia' instruments

MODELS AFFECTED: Commando (Interstate and Roadster)

DISTRIBUTION: General Distribution (Worldwide)

EXPLANATION: Instruments manufactured by an alternative supplier are now specified for fitment on Interstate and Roadster models.

Due to the increased depth of these 'Veglia' instruments, instrument cases of deeper section are also incorporated in conjunction with the new type of Tachometer and Speedometer.

Smith's instruments will continue to be fitted in pairs to the other models in the range, utilising the earlier instrument case 060510 gear ratios, cable rotations and connections are common for both Smith's & Veglia instruments.

ACTION:

New part numbers introduced are as under:-

Speedometer M.P.H. (Veglia)	063790
Speedometer K.P.H. (Veglia)	063798
Tachometer (Veglia)	063791
Instrument case	0 6 3 7 5 8

NOTE: The deeper instrument case, part number 064144, may be used (in pairs only) in conjunction with Smiths instruments when 2 off fixing stud extensions, part number 061281, will be required.

Veglia speedometers incorporate a 'Trip' odometer mileage recording mechanism.

Service Arrangements. In Europe, existing Veglia instrumentation is already fully supported by the manufacturer. In U.K., Veglia instruments are serviced through Messrs. Auto Tempo Meter Company Limited, 140/2 Kings Cross Road, London W.C.1., to whom all instruments and service correspondence should be addressed. In the U.S.A., Nisonger Corporation will undertake Veglia service in addition to Smiths Instruments.

Service arrangements elsewhere will be through normal Norton Distributor service channels until alternative arrangements can be made.

JANUARY 1973



---

 SERVICE RELEASE

NO. N3/28

CATEGORY OF RELEASE

4

NATURE OF RELEASE

Improved Clutch Capacity

MODELS AFFECTED

Commando (All Models)

DISTRIBUTION

General Distribution (Worldwide)

EXPLANATION

A new type of clutch friction plate was introduced on to production models at engine number 212278.

The new plate comprises two sintered bronze friction discs bonded to either side of a plain steel plate. Extra clutch capacity is provided by the inclusion of 5 friction plates in place of the original four fibre material type.

Additional changes are the incorporation of an additional plain driving plate and an identical but heat treated and hardened clutch centre, together with a new thinner section pressure plate.

ACTION

The new clutch components are fully interchangeable as indicated:

Clutch drive plate (plain)	060746 4off was 060746 3off
Clutch driven plate (friction)	063741 5off was 0613394off
Clutch pressure plate.	063768 1off was 060745 1off
Clutch centre	063979 1off was 060743 1off

Clutch assembly complete 064104 was 062481.

NOTE: The new hardened clutch centre 063979 can be used with earlier clutch assemblies, but under no circumstances should the new sintered faced driven plates be used unless in conjunction with the new 063979 hardened clutch centres (identified by its darker "Heat Treatment" colouration).

NOVEMBER 1972

## SERVICE RELEASE

N3/30

CATEGORY OF RELEASE: 4

NATURE OF RELEASE: Battery preparation prior to installation

DISTRIBUTION: Worldwide - General Distribution

EXPLANATION: Introduction of the Yuasa battery onto standard motorcycle production necessitates clarification of the recommended methods of introduction into service, to ensure maximum life availability of the battery.

Batteries affected:

Norton Villiers No.033049 - Lucas PUZ5A  
Norton Villiers No.063244 - Yuasa 12N9-4B

ACTION:BATTERY PREPARATION PRIOR TO INSTALLATION

1. Remove all sealing and battery vent plugs. Where a long vent tube is fitted cut off the sealed end of the pipe. If a short sealing tube or cap is fitted, pull off and replace with the long pipe.
2. Filling. Fill battery with Electrolyte (dilute Sulphuric Acid) specific gravity as indicated below and cooled below 30°C. (86°F.) before filling:-

Temperate climate (normally below 80°F.(25°C))	1.260
Tropical climate (normally above 80°F.(25°C))	1.240 (Yuasa) 1.210 (Lucas)

Fill each cell to the upper level indicated on the case. Leave the battery to stand at least half an hour after 'filling (no longer than two hours). Open circuit volts should read 10 to 12½ volts. Re-adjust levels to maximum level mark adding or taking out acid (not water).

3. Initial Charging. Charge battery as indicated below:-

Make	<u>Charging Current</u>	<u>Period (Hours)</u>
Lucas	$\frac{3}{4}$	4
Yuasa	$\frac{1}{2}$	15 - 20

After charging, re-adjust levels using Distilled Water to the upper level mark. Clean the battery carefully with fresh water and a damp cloth. Refit the vent plugs/cover, press home firmly, and dry the battery. Smear the terminals with Petroleum Jelly (not grease).

4. Installation. Fit the battery to the motorcycle, routing the vent tube to below the lower frame level to direct any acid fumes away from affected areas. Do not fold or crimp the vent tube. It may cause an explosion if the tube is sealed or trapped.

## 4. Cont.....

Connect the Negative (Brown/Blue) cable to the battery Negative (-) terminal, followed by the Positive (Red) cable to the battery Positive (+) terminal. Be sure not to reverse these connections or damage will occur to both the rectifier and zener diode..

5. Maintenance. Check the Electrolyte level once a month. Restore to the upper level using Distilled Water. Never use acid. Always keep the battery clean. Apply Petroleum Jelly around the terminals to prevent corrosion. Keep the vent tube free from kinks or obstructions.
6. Recharging. Where insufficient running allows the battery to become low in charge or the battery has been unused for longer than a month, apply a freshening charge of  $\frac{1}{2}$ amp until the battery is gassing freely and the specific gravity rises (higher than 1.240 in tropical climates) (higher than 1.260 in temperate climates)
7. Recovery of Stock Batteries. If a battery has remained in new shelf stock for more than ten months, Lucas recommend that the four hour 'freshening' charge (Section 3) should be extended to a minimum of 12 hours.
8. Service arrangements. Lucas batteries continue to be serviced through recommended existing Lucas service channels for supply, service and guarantee purposes as previously. Yuasa batteries fitted to Norton machines are guaranteed by Norton Villiers, the warranty being handled exclusively and - in the same way as other Norton Villiers components.



SERVICE RELEASE

No. N3/31

NATURE OF RELEASE: Removing auto-advance mechanism

MODELS AFFECTED: All Commando with timing cover contact breaker

DISTRIBUTION: Worldwide (General Distribution)

EXPLANATION: Due to possible manufacturing variations, removal of the auto-advance mechanism utilising a straight pull with the extended centre bolt tool 060934 can result in the mechanism subsequently jamming. We therefore recommend future removal, partly by end pressure and partly by tapping sideways to "break" the tapered joint between the auto-advance shaft and camshaft.

ACTION: Remove the centre bolt and washer from the auto-advance mechanism. Insert auto-advance extractor bolt 060934 and partial tighten only. Tap sideways very lightly on the extractor bolt and the tapered joint will be parted without risk of spreading the auto-advance unit shaft at the cam bearing.  
(Warning: The auto-advance unit tapered section of the camshaft is manufactured in a fully annealed condition, and will be damaged if excessive side shock loading is applied).

JANUARY 1973





---

**SERVICE RELEASE**

N3/32

CATEGORY OF RELEASE: 5

NATURE OF RELEASE: Wheel balance weights

MODELS AFFECTED: Commando (all models)

DISTRIBUTION: General Distribution (worldwide)

EXPLANATION: Wheel balance weights have now been introduced onto general production (with effect from Engine Number 300,003) designed to fit axially onto the wheel spoke nipple itself.

ACTION: The new slotted 'cone' weights entirely supersede the earlier adhesive pattern, and should be stocked under the following Part Numbers:

Front Wheel (0.025in. (0.64mm) nipples) (Disc)

064618 Wheel balance weight	17 grammes
064020 Wheel balance weight	25 grammes

Rear Wheel (0.030in. (0.76mm) nipples) & Front Wheel (Drum)

064617 Wheel balance weight	17 grammes
064619 Wheel balance weight	25 grammes

Care should be taken to use the correctly dimensioned weights appropriate to each wheel - which should be driven 'snugly' home over the required spoke nipple.

FEBRUARY 1973



---

SERVICE RELEASE

N3/33

CATEGORY OF RELEASE: 3

NATURE: OF RELEASE: Inlet valves incorporating stellite tip.

MODELS AFFECTED: All Commando

DISTRIBUTION: General Distribution (worldwide)

EXPLANATION: An improved inlet valve incorporating a stellite material hardened tip, similar to the exhaust valve has been fitted as standard on production models from Engine Number 221317.

ACTION: **The** new inlet valve Part Number 064034 is fully interchangeable with previous types NM25501 and 063283 and should be used for all replacement purposes.

FEBRUARY 1973



SERVICE RELEASE

No. N3/34

CATEGORY OF RELEASE: 5

NATURE OF RELEASE: Rear brake shoes and slippers

MODELS AFFECTED: All Commando

DISTRIBUTION: General Distribution (worldwide)

EXPLANATION: In order to simplify stocking procedures, and clarify assembly details, rear brake shoes complete with lining, Part Number 060828 will in future be serviced and supplied under the following Part Numbers only:

063417 Rear brake shoe c/w liner - without slipper  
060013 Brake shoe slipper

ACTION: In future, orders placed for brake shoe 060828 will be supplied with **063417** (less slipper).

Ensure that orders placed for replacement brake shoes (where slippers are required) clearly detail 060013 slipper as additional requirements.

FEBRUARY 1973



---

 SERVICE RELEASE

No. N3/35

CATEGORY OF RELEASE: 5

NATURE OF RELEASE: Con-rod big-end shell 'packaging'

MODELS AFFECTED: Commando (all models)

DISTRIBUTION: Worldwide (General Distribution)

EXPLANATION: To bring spares supply in line with current requirements, future demands for replacement con-rod big-end shells will be in pairs, i.e. one upper shell and one lower shell, wrapped and boxed as a pair.

Listed Part Number changes are as under.

ACTION: Orders for replacement shells should now be placed in accordance with the following list. (No dimensional or specification changes are involved).

<u>New Part Number</u>	<u>Size/Oversize</u>	<u>Description</u>	<u>Replacing</u>
064285	Std.	B / E shells	(NM25384 (NM23255
064286	+010	B/E shells	(NM25409 (NM25165
064287	+020	B/E shells	(NM25410 (NM25166
064288	+030	B/E shells	(NM25411 (NM25167
064289	+040	B/E shells	(NM25412 (NM25168

FEBRUARY 1973



## SERVICE RELEASE

N.3/36

CATEGORY OF RELEASE: . 5

NATURE OF RELEASE: Model **149** SA ignition and lighting switch.

MODELS AFFECTED: Commando (all models)

DISTRIBUTION: General Distribution (worldwide)

EXPLANATION: The four terminal version of the above switch was introduced onto Norton Commando models from Engine Number 200,000.

This later switch now directly supersedes the earlier three terminal version, but will require minor wiring harness alterations and alternative wiring terminal connections. If wiring to the later standard is required Part Number **39565** three terminal version. Part Number **39784** four terminal version.

ACTION: (Quoted from February **1973** Lucas Service Information Note SI/SW/45.)

When replacing a three terminal unit by a four terminal unit Part No. **39784**, terminal No. 4 should be disregarded. However, if it is required to modify the motorcycle to the later standard, and use the new switch as the master unit for ignition, pilot and headlamp, proceed as follows:- .

1. Inside the headlamp disconnect the blue lead from the lighting switch and tape back the free end.
2. Locate the dip switch. Disconnect the blue lead at the nearby snap connector. Leave free the short lead attached to the dip switch and tape back the remaining end.
3. Connect a new blue lead (cable size 14/.010" (14/0.25mm) between terminal No.4 of the master switch Part No. **39784**, and the free end of the blue lead attached to the dip switch.

Ensure the new lead is securely taped to the existing main harness.

NOTE: The headlamp main or dip beam will still be selected by the handlebar dip switch.

FEBRUARY 1973



SERVICE RELEASE

No. N3/37

CATEGORY OF RELEASE: 2

NATURE OF RELEASE: Front forks - recommended lubricants

MODELS AFFECTED: All Commando

DISTRIBUTION: Worldwide - General Distribution

EXPLANATION: In order to bring the current Factory recommendations in line with the latest lubricant manufacturers products and practices, the following revised list of alternative Factory oil recommendations is given below.

ACTION: Each fork leg should be drained and refilled with 150 c.c. (5 fl.oz.) of one of the following alternative lubricants.

- Castrolite 10W/30
- BP Super Viscostatic 10W/40
- Shell Super Motor Oil
- Mobiloil Super
- Esso Uniflo
- Duckhams Q5500
- Texaco Havoline Motor Oil 10W/30
- Sunoco Special Motor Oil 20W/50
- Filtrate A.T. Fluid F.

FEBRUARY 1973



SERVICE RELEASE

No. N3/38

CATEGORY OF RELEASE:

5

NATURE OF RELEASE:

Top engine mounting - engine steady plate

MODELS AFFECTED:

Commando (all models)

DISTRIBUTION:

Worldwide (General Distribution)

EXPLANATION:

An improved version of the original engine steady Part Number 060498 is now available under the new Part Number 064179.

The new head steady has been fitted to production machines from Engine Number 220,000. It is of stiffer construction, and is fabricated as a "box section" member.

It is fully interchangeable with 060489.

ACTION:

Do not attempt to re-weld or re-claim failed or fractured samples of the earlier type steady 060489. As experience has shown this will only encourage subsequent fracture.

Replace using the new type 064179.



---

 SERVICE RELEASE

No. N3/39

CATEGORY OF RELEASE: 5

NATURE OF RELEASE: Replacement centre stand kit

KODELS AFFECTED: Commando 1971 to 1973 (up to Engine No. 300,000)

DISTRIBUTION: Worldwide (General Distribution)

EXPLANATION: An extremely robust centre stand has been introduced for all Commando after Engine Number 300,000 (and was also incorporated on Engine Number 221545 to 221644 and 230536 to 230685).

This new stand is suitable for use of all Commando that have the stand pivoting directly on the Isolastic engine plates - that is, 1971 models onwards; however, a special spacer bush is needed for this purpose.

For this reason, kit 064874 has been introduced. This kit contains all the parts needed to fit the new centre stand to previous Commando models.

Contents of kit are:

064031	Centre stand	1
064643	Spring	1
064873	Spacer	2
062040	Bolt	2
		2
005202	Washer	4

Fit the new centre stand 064031 to all Commando's subsequent to 1971 models, utilising kit 064874 on models up to 300,000 (except for engine numbers 221545 to 221644 and 230536 as noted above).

MARCH 1973





## SERVICE RELEASE

NO. N3/40

CATEGORY OF RELEASE 5

NATURE OF RELEASE Handlebar Switches

MODELS AFFECTED 1971/2/3 Commando

DISTRIBUTION Worldwide (general distribution)

EXPLANATION In order to clarify difficulties that have arisen in part number description in parts listing subsequent to the reversal of location of the two Lucas handlebar switches on late 1972 models (see Service Release N3/3), a list is provided below indicating switch function against part number and location.

X ACTION Before ordering replacement switches, check the switch function in preference to L.H. or R.H., description in the 1971 and 1972 parts list.

	Switch Only	Pivot Casting	Switch/Pivot Casting Assy	Switch Only	Pivot Casting	Switch/pivot Casting Assy
Dip & Flasher	54033666	54340883 (clutch alloy)	39595	39949	063678 (clutch black)	No longer supplied
Switch	54033666	54343791 (clutch black)	39758			
Direction Indicator	54033667	54340882 (Fr. brake alloy)	39596	39951	For use with master cyl 064635 (Fr brake black H/Rider only)	No longer supplied
Switch				39951		

Drum Fr. brake/Clutch screws 062488 4 off each  
Master cylinder screws 062241 4 off

NORTON VILLIERS CANADA LIMITED

April 1973



---

**SERVICE RELEASE**

CATEGORY OF RELEASE 5

NATURE OF RELEASE Swinging arm

MODELS AFFECTED All Commando up to 1973

DISTRIBUTION Worldwide (general distribution)

EXPLANATION The Commando rear swinging arm has been stiffened by the incorporation of box section gusset plates, providing improved rigidity.  
The new swinging arm completely replaces the previous component and was fitted as standard from Eng No 300,003

ACTION Order 064539 in place of previous swinging arm 060441.

April 73.



## SERVICE RELEASE

N3/43

CATEGORY OF RELEASE: 2

NATURE OF RELEASE: Auto-advance unit - periodic lubrication

MODELS AFFECTED: All Commando

DISTRIBUTION: Worldwid: (General Distribution)

EXPLANATION: Following the investigation of auto-advance units returned for exchange under the terms of the recent 1972 Combat model programme - for the latest heat treated unit (Part Number 5442 5656), examination has revealed widespread lack of regular attention, particularly in respect of the cam/spindle bearing surface and the centrifugal weights and pivots.

ACTION: Owners and workshops should be made fully aware that regular and positive lubrication should be applied to the following bearing surfaces:

1. Cam and spindle
2. Centrifugal weight pivot pins
3. Centrifugal weight cam guide slots

A smear of light Molybdenum based grease should be applied to the auto-advance cam bore and spindle, centrifugal weight pivot pins and cam guide slots at the 500 mile, (800 km) service and every 3,000 miles (5,000 Km) thereafter. Extreme care must be taken not to distort or stretch the advance unit control springs during the dis-assembly and re-assembly operation.

It should be noted that our experience indicates the timing cover contact breaker compartment now remains substantially dry and free of lubricating oil mist subsequent to the introduction of the later (red identification) oil seal part number 063609 from engine number 212303 onwards.

APRIL 1973



## SERVICE RELEASE

NO. N3/44

CATEGORY OF RELEASE 6

NATURE OF RELEASE Front Wheel Disc Brake

MODELS AFFECTED 1972/3 Commando

DISTRIBUTION Worldwide (general distribution)

EXPLANATION It has come to our notice that instances have occurred where owners of 1972/3 Commando models have reversed the assembly of the front fork sliders in order to fit the front brake caliper forward of the left fork slider. This can be accomplished with the minimum modification to Hydraulic pipework and Mudguard (fender) stay alteration.

ACTION Norton Villiers Limited wish to bring to the notice of all concerned that such alteration to the designed specification may constitute a hazard to the rider.

The front wheel bearing (L/H) lockring has right hand thread. When the front wheel is reversed to fit the above unauthorised layout there is a possibility of the lockring loosening, in which case the disc would become mis-located in the caliper, creating an extremely hazardous condition

March 73.



## SERVICE RELEASE

<u>CATEGORY OF RELEASE</u>	4
<u>NATURE OF RELEASE</u>	Front and rear tyre fitment procedure
<u>MODELS AFFECTED</u>	All Commando
<u>DISTRIBUTION</u>	Worldwide (general distribution)
<u>EXPLANATION</u>	<p>In order to improve the overall tyre performance, tyre manufacturers are currently introducing moulded 'arrows' into the 4.10 and 4.25 cover sidewalls, indicating the recommended direction of rotation which must be observed when fitting to front and rear wheel rims.</p> <p>It will be appreciated that for the rear wheel the arrow takes into consideration the direction of tractive effort whereas the effect is reversed (i. e braking effort) where fitted to the front wheel.</p>
<u>ACTION</u>	<p><u>Rear Wheel:</u> Fit 4.10 and 4.25 tyres (incorporating moulded sidewall arrows indicating recommended direction of rotation) with the 'rear wheel' arrow pointing in the direction of rotation of the rear wheel.</p> <p><u>Front Wheel:</u> Fit 4.10 and 4.25 tyres (incorporating moulded sidewall arrows) to the front rim with the "Front Wheel" arrow pointing in the direction of rotation of the front wheel.</p>

April 73.

## SERVICE RELEASE

CATEGORY OF RELEASE: 4

NATURE OF RELEASE: Recommended assembly sequence - exhaust system

MODELS AFFECTED: **1973 850** c.c. Commando

DISTRIBUTION: Worldwide (General Distribution)

EXPLANATION: Below is an extract of publication NV1300 "Fitting Exhaust System - Assembly Sequence" which is now included with the **instructional** literature in each new motorcycle case.

In order to eliminate possible stresses introduced into the exhaust system during assembly and fitting, follow the procedure outlined **below:-**

- ACTION:
1. Fit L.H. exhaust pipe complete with lockring, sealing and tab washers. Run up **lockring** but do not tighten at this stage.
  2. Fit L.H. muffler to exhaust pipe, align the mounting pommels and assemble loosely to the L.H. muffler bracket mounting rubbers.
  3. Fit R.R. exhaust pipe complete with **lockring** sealing and tab washers. Run up **lockring** but do not tighten.
  4. Fit R.H. muffler to exhaust pipe, align the mounting pommels and assemble loosely to the R.H. muffler bracket mounting rubbers.
  5. Slide both connector sleeves to the centre of the cross tube. Place cross tube in position and slide both connector sleeves outwards to engage with the **exhaust** pipe stubs.
  6. Slacken off all **footpeg support** and muffler bracket bolts in the left and right hand aluminium support plate castings - to allow the bracket to swivel and adjust to the exhaust pipe/muffler alignment.
  7. Tighten up the total exhaust system, commencing at the cylinder head lockrings and cross tube connector sleeves. Do not forget to bend up the **lockring** tab washers.
  8. Finally retighten the muffler **bracket/support** plate bolts.

MAY 1973



## SERVICE RELEASE

N3/47

CATEGORY OF RELEASE: 4

NATURE OF RELEASE: Lubricating Oil Recommendations

MODELS AFFECTED: All Commando

DISTRIBUTION: Worldwide (General Distribution)

EXPLANATION: Development testing has now been concluded on the full application of lubricants manufactured by Gulf Oil (Great Britain) Limited.

Recommendations are listed below:-

Engine: Gulf Formula G.40

or

Gulf Multi-G. 20W/50

Primary Chaincase: Gulf Multi-G. 20W/50

Gearbox: Gulf Multi Purpose Gear Lubricant 90

Swinging Arm Bushes: Gulf Filtri Purpose Lubricant 140

Hub and Frame Parts: Gulf Crown Grease No.2

or

Culflex A

Front Forks: Gulf Multi-G. 10W/30

Rear Chain: Gulflex Moly

Easing Rusted Parts: Gulf Penetrating Oil G.

It will be noted Monograde SAE40 oils have been given the preferred recommendation for engine application, which will also be incorporated for all other brands where applicable. (Monograde SAE30 equivalent for winter running conditions).

The above recommendations will be included in the Rider Handbook recommendations, Service Voucher Booklets and Workshop Manuals at the next convenient opportunity.

MAY 1973



SERVICE RELEASE

N3/48

CATEGORY OF RELEASE:

2

NATURE OF RELEASE:

Carburettor, Needle Settings.

MODELS AFFECTED:

1973 850 c.c. Commando model

DISTRIBUTION:

Worldwide (General Distribution)

EXPLANATION:

Owners report a very slight hesitation on rapid throttle openings from a "standing start" or in the intermediate gears which can be cured by raising the carburettor slide needle.

ACTION:

Raise the carburettor needles one notch to the central (one below top) groove at the next convenient opportunity.

Dealers should make a point of amending stock machines to the recommended setting during initial set-up procedures.

MAY 1973





## SERVICE RELEASE

N3/49

CAFEGGRY OF RELEASE:

3

NATURE OF RELEASE:

Symptoms of Pre-Ignition

MODELS AFFECTED:

1973 850 c.c. Commando model

DISTRJBUTION:

Worldwide (General Distribution)

EXPLANATION:

Symptoms of mild pre-ignition at low engine R.P.M. on sudden throttle openings are eliminated by removal of sharp edges and corners in the combustion sphere.

ACTION:

On machines reporting pre-ignition symptoms, remove the copper cylinder head gasket and, using a small flat scraper, remove and blend the sharp edges on both sides of the gasket cylinder bore piercings.

It is also recommended that at the same time the top corner of each cylinder bore is scraped and blended to remove any possibility of sharp edges or 'burrs'. Great care must be taken to ensure no abrasive particles whatsoever fall into the cylinder bore and lodge between the piston top land, top compression ring and cylinder wall during this operation.

Check the cylinder head prior to replacement and remove any sharp spark plug thread 'run-out' into the combustion sphere.

Finally, check the carburettor needles arc located in the central (one below top) groove as recommended in Service Release N3/48.

MAY 1973

## SERVICE RELEASE

N3/51

CATEGORY OF RELEASE: 3NATURE OF RELEASE: Cylinder Head Steady - Recommended Assembly SequenceMODELS AFFECTED: Commando (All Models)DISTRIBUTION: Worldwide (General Distribution)

EXPLANATION: It has been established that residual engine vibration can be minimised, particularly at low engine R.P.M. by taking particular care in the method of assembly of the head steady to the cylinder head, and to the frame engine steady rubber mountings.

ACTION: Place the machine on the centre stand. Remove the fuel tank. Remove the cylinder head steady. If not already fitted, fit the box section head steady 064179 (see Service Release N3/38) utilising a flat steel tank washer 014999 (1.25 in. (31.75mm) O.D.X. .328in. (8.33mm) bore x .080in. (2.031mm) thick) under the head and spring washer of each of the two outer engine steady to head socket screws.

The flat washers locate the head steady in its most forward slot location. Assemble finger tight only,

Offer up and assemble the two engine steady side plates and studs, washers and nuts onto the frame engine steady rubber mountings. Some pre-loading may be necessary due to the new forward location of the head steady. Tighten up the two lower side plate stud nuts. Tighten all the remaining screws and nuts progressively and in sequence, which will then pre-load the engine steady rubber mountings, with those nuts being tightened last.

Important Note:

For optimum engine vibration insulation, it is recommended that the stipulated 0.010in. (0.25mm) Isolastic mounting clearance is set to provide 0.005in. (0.13mm) per side when at rest, without any side load pressure being applied.

The above procedure will ensure that the engine will be provided with the correct support under riding conditions.

MAY 1973



## SERVICE RELEASE

No. N3/52

CATEGORY OF RELEASE: 5

NATURE OF RELEASE: Improved material "cut-out" decals

MODELS AFFECTED: All Commando

DISERIBUTION: Worldwide (general release)

EXPLANATION: A new **range** of tank and side cover decals have been introduced providing improved design features including "cut-out" pre-spaced letters for ease of fitting to the double curvature tank surface, improved decal plastic material and a stronger adhesive base to withstand rugged service and adverse conditions.

The new decals featuring the "cut-out" facility are more attractive, and are much more positive and easy to apply.

The list below completely replaces all previous Commando tank 2nd side cover decals.

ACTION: Replace all existing 750c.c. and 850c.c. Commando decals when required, 2s listed below:-

### Tanks

064880	Decal "Norton"	(Cold)
064881	Decal "Norton"	(Black)
064882	Decal "Norton"	(Silver)

### Side Covers

065096	Decal 850 Commando	(Cold)
065097	Decal 850 Commando	(Black)
065095	Decal 850 Commando	(Silver)

MAY 1973



## SERVICE RELEASE

No. N3/53

CATEGORY OF RELEASE:

5

NATURE OF RELEASE:

Rear mudguard mud-flap

MODELS AFFECTED:

All Commando

DISTRIBUTION:

Worldwide (All markets)

EXPLANATION:

To meet specific market requirements a rear mudguard mud-flap has been introduced which is also to be made available to all markets through normal parts outlets.

ACTION:

The following parts are required:

- 1 065092 Mud-flap (includes 064880 Gold Decal)
- 1 065046 Mud-flap bracket

The mud-flap is fitted under the tail-end of the rear mudguard, and is sandwiched and located using the mud-flap bracket which then bolts in position utilising the two lower tail light fairing retaining bolts.

MAY 1973



## SERVICE RELEASE

No. N3/54

CATEGORY OF RELEASE: 5

NATURE OF RELEASE: Passenger grab rails

MODELS AFFECTED: All "Roadster" and "Interstate" Commando models

DISTRIBUTION: Worldwide (General distribution)

EXPLANATION: In order to commonise grab rails for both Roadster and Interstate models, a commonised grab rail has been issued.'

ACTION: Future requests for 063632 Interstate grab rail and 063819 Roadster grab rail should be met with the supply of the commonised grab rail part number 064978.

The following additional parts should be used:

063798	Clips	4	off
26948	Bolt	4	o f f
062240	Nut	4	off
30858	Washer	4	off

NOTE : Hi-Rider grab rails 062374 (1971/72 models) and 064088 (1973 models) are not interchangeable, and continue to be serviced.

MAY 1973

# SERVICE RELEASE

No. N3/55

motorcycles

- CATEGORY OF RELEASE: 5
- NATURE OF RELEASE: Introduction of rear chainguard extension
- MODELS AFFECTED: All Commando
- DISTRIBUTION: Worldwide (General distribution)
- EXPLANATION: A new rear chainguard has been introduced on assembly subsequent to engine number 307091 which incorporates a detachable extension piece.
- The new chainguard 064837 is similar to the superseded part 061865 but incorporates two additional pierced holes into which the additional plastic extension piece locates.
- ACTION:
- To replace existing chainguard 061865 use the following components:-
 

1	064837	Chainguard
1	064822	Chainguard extension
2	06L. 823	Chainguard extension button
1	064824	Chainguard extension spring
  - To convert existing chainguard 061865 to accept and fit the new chainguard extension assembly, modify as shown below.

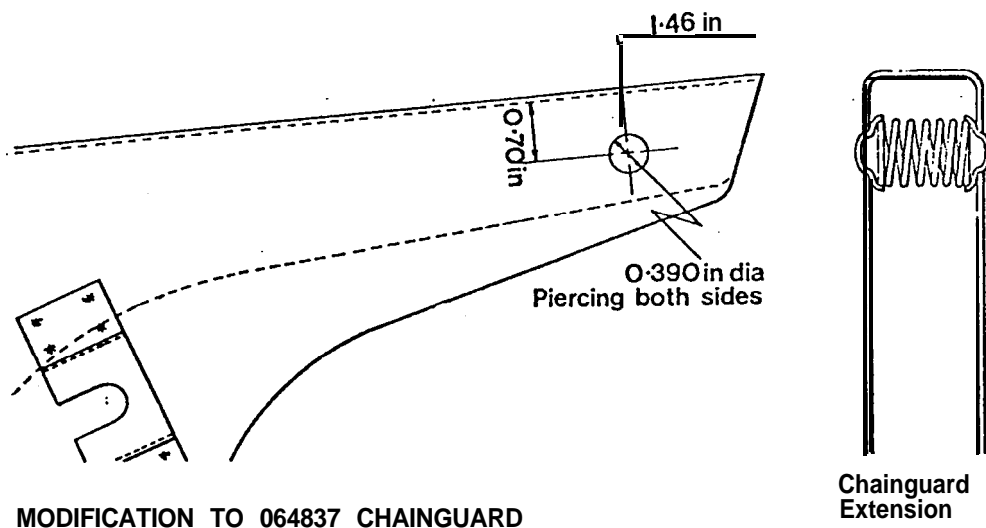

- Stocks of the previous chrome plated rear chainguard 061272 with the rounded tail end are still available and can be obtained through the normal parts outlets.

HDP © 1999

**Norton**

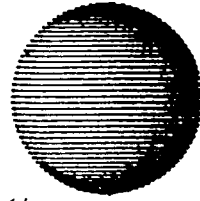

## SERVICE RELEASE

*n/3/56*

---

### 1973 850 **MODEL COMMANDO** **HIGH PERFORMANCE MODIFICATION** **INSTRUCTIONS**

---

Conversion instructions from Standard Road Specification to High Performance Sports Condition.

The following components will require replacement or modification to achieve the recommended specification.

1. Camshaft replacement to 'SS' Sports specification.
2. Piston modification to Sports condition.
3. Cylinder head Conversion to Full Flow 'High Compression condition.
4. New Amal Velocity Stacks for Carburettors.
5. Push rod modification.

The accompanying instructions detail the alterations that are necessary to convert existing components to the recommended condition.

Cutaway outlines are provided to guide the enthusiast in achieving the recommended optimum port shapes, together with the drawings illustrating the necessary alterations to Push rods and Piston Crown configurations to accommodate the increased compression ratio and valve opening.

For owners and riders wishing to fit Transistorised Electronic Ignition equipment, detailed fitting and set up instructions are provided in the Norton Villiers publication part number 065151 "Boyer Electronic Ignition" obtainable through Norton spares outlets, or from the local Norton Distributor.

Conversion to the factory recommended High Performance condition involves the following operations, achieved either by replacement, or conversion of the existing components as detailed below.

- Camshaft → Replacement of the existing camshaft with 063536 'SS' camshaft.
- Piston (850 cc) → Conversion to High Performance/ High compression condition.
- Velocity Stacks (for carburettor) → Replacement of existing air filter equipment with alternative Amal components.
- Push Rods → Modifications to accommodate the alterations to the cylinder head configurations.

For those wishing to convert the original pistons and cylinder head to the recommended condition the following instructions are provided, and should be carefully adhered to. Modifications are also recommended to push rod lengths to compensate for the alteration to rocker geometry resulting from cylinder head gasket face removal.

Modification required to Existing Components

1. Piston Conversion of the standard 850 piston 063836 to sports condition involves deepening the valve 'cut-away' pockets in accordance with the dimensions given in Fig. 1.

The cut-aways require re-machining to the amended conditions as shown to allow for the additional 'valve drop' created by the use of the new Camshaft 063536. The head diameters of both the inlet and exhaust valves should be measured → ensure head diameters do not exceed 1.490 in. (37.85 mm) inlet, and 1.302 in. (33.07 mm) exhaust. This will avoid any possibility of subsequent 'hook up' when using 063536 Camshaft in the higher engine R.P.M., range.

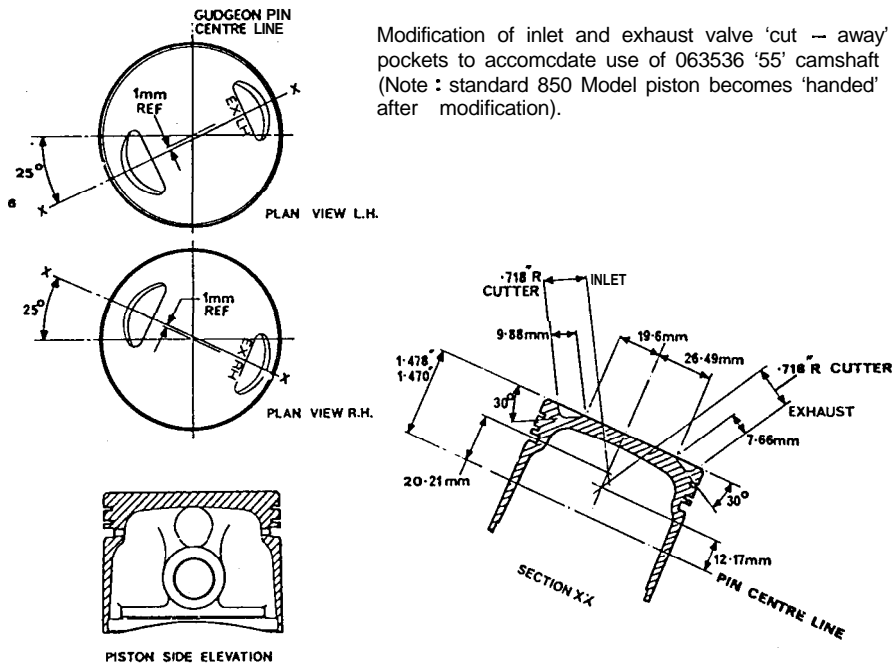

Modification of inlet and exhaust valve 'cut - away' pockets to accommodate use of 063536 '55' camshaft (Note : standard 850 Model piston becomes 'handed' after modification).

FIG. 1. PISTON CROWN MODIFICATION



Following modifications to both the ~~pistons and the~~ cylinder head, it is advisable to check the actual available 'valve drop' by placing modelling clay (**Plasticine**) into the valve clearance 'cut —always' and rotating the crankshaft at least two complete revolutions. Measure the thickness of the modelling clay. A minimum clearance of 0.030 in / 0.040 in (0.75mm/1.0mm) must be allowed when the inlet valve is closest to the piston at 3° / 5° A.T.D.C.

2. Cylinder Head Modifications required to convert the standard 850 cylinder head 063830 to the recommended High Performance condition.

The diagram (Fig. 2) details the modifications that are recommended to increase the compression ratio to 10:1, and to convert both inlet and exhaust ports to the recommended shape to provide optimum power with flexibility.

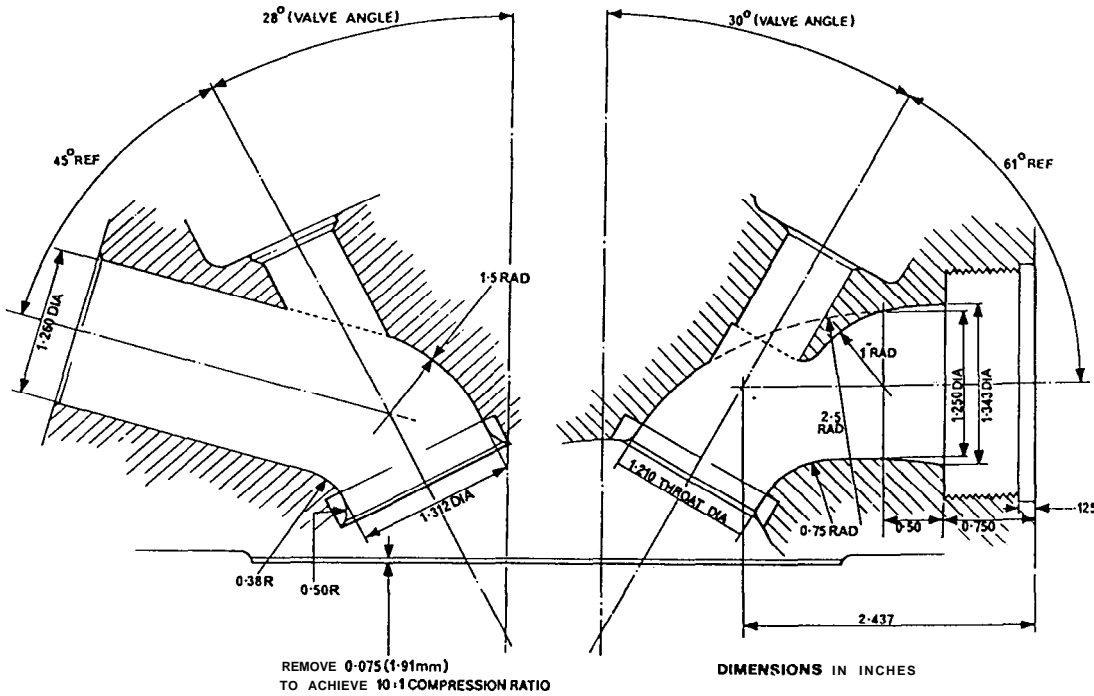

FIG. 2. CYLINDER HEAD MODIFICATION

We do not recommend excessive polishing of inlet and exhaust ports. Consistent shape and port cross sectional area is far more important for gas flow than highly polished sidewalls

Removal of excess material in the Inlet and Exhaust port areas should be undertaken using a rotary file, or similar equipment. Particular care must be taken not to damage valve seat inserts and valve seatings when blending the ports from within the combustion sphere area.

The removal of material from the cylinder head gasket face should be entrusted only to specialists in this field, who have the equipment designed to maintain correct depth of cut with absolute flatness and truth during this operation.

If in any doubt whatsoever, the total operation should be undertaken only by specialist machinists engaged in this type of work.

### 3. Push Rods

In order to maintain correct rocker geometry following removal of material from the cylinder head gasket face it is recommended that both end caps are removed from each of the four push rods, and 0.037 in (0.95mm) of metal removed from each end of the push rod prior to replacement of the end caps. Do not remove all the metal from one end only of the push rod as this may result in the end caps not re-seating properly, and only partially resting onto the taper run-out of the push-rod itself (see Fig. 4.).

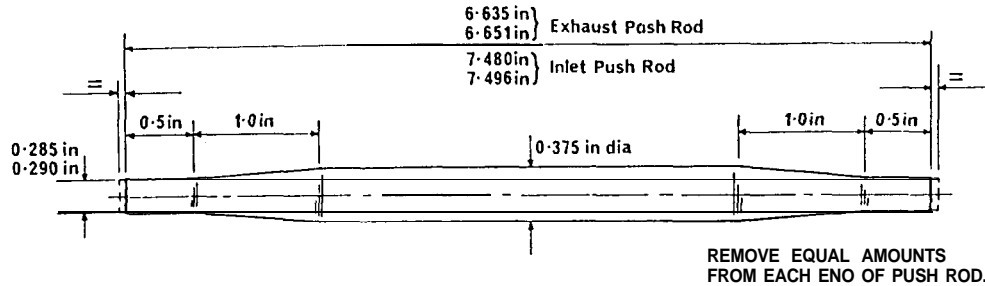

**FIG.3 PUSH ROD MODIFICATION**

### 4. Ignition Timing

Valve Clearance 'SS' Camshaft Part No. 063536

(Contact Breaker)	Inlet 0.008 in (0.2mm)
30° B.T.C. Max. Advance	Exhaust 0.010 in (0.25mm)
@ 3000r.p.m.	
(Electronic Ignition)	
31° B.T.C. Max. Advance	
@ 5000r.p.m.	

### 5. Carburettors

Standard 32mm carburettors as supplied with the machine give optimum performance utilising Amal Bell Mouth Velocity Stack.

Further detailed information is provided to assist in any subsequent incorporation of Electronic ignition equipment. Norton Villiers Publication part number 065151 "Boyer Electronic Ignition" is available through normal Norton Service Channels.

### Warning

Although every attempt has been made to convey factory experience and recommendations in this publication, Norton Villiers Ltd. (or its representatives) cannot be held responsible for ultimate performance or reliability resulting from this conversion.

On completion, it is emphasized that the engine should be run only on a minimum of 100 Octane grade fuel. Also due to the increased efficiency and immediate response of the modified engine unit, great care must be taken not to over-rev the engine in the intermediate gears.

The fitting of oversized high tensile centreless ground bolts into sized and reamed crankcase boss and rear engine mounting bolt holes is advised to ensure maintenance of maximum rigidity of assembly.



---

SERVICE RELEASE

N3/57

CATEGORY OF RELEASE: 3

NATURE OF RELEASE: Rear chain oiler regulator adjuster

MODELS AFFECTED: Commando (All models)

DISTRIBUTION: Worldwide (General Distribution)

EXPLANATION: An adjuster facility has been added to the rear chain oiler regulator assembly (from engine introduction number 302000) by means of an additional clamp, part number **064875**.

The clamp is in the form of a compression clip, and is applicable to all previous Commando models utilising rear chain oiler regulator assembly 061669.

ACTION: For machines exhibiting symptoms of excess rear chain lubrication, fit the rear chain oiler regulator adjuster **064875**. It should be noted that the regulator can be adjusted to completely shut off the oil flow to the rear chain where required. Care must be taken in final positioning, to avoid contact or interference with the battery, other electrical equipment, or wiring.

JULY 1973



---

## SERVICE RELEASE

N3/58

CATEGORY OF RELEASE: 5

NATURE OF RELEASE: Lucas Auto-advance Mechanism

MODELS AFFECTED: All Commando models

DISTRIBUTION: Worldwide (General Distribution)

EXPLANATION: With the introduction of the 10CA contact breaker assembly, the auto-advance mechanism has been allocated a new part number,

The new part number (which was **54425656**) is now:-

**54426429**

The two units are completely interchangeable. The later unit incorporates all the improved features of the earlier version, and directly supersedes all previous auto-advance mechanisms.

JULY 1973



SERVICE RELEASE

N3/59

CATEGORY OF RELEASE: 4

NATURE OF RELEASE: Recommended Engine Lubricants

MODELS AFFECTED: All Commando

DISTRIBUTION: Worldwide (General Distribution)

EXPLANATION: Important amendments to all previously issued engine lubricant recommendations have now been confirmed by the Norton Development Department (see also Service Release N3/47 May '73).

H.D. SAE40 Monograde oils meeting A.P.I. service SE or SD performance level now form the preferred engine lubricant recommendations for both current and previous 750/850 models.

(SAE 30 equivalents for ambients below 32°F. (0°C.)  
 (SAE 50 equivalents for ambients above 90°F. (32°C.)

The previously recommended Multi-Grade lubricants continue with full approval for use, but it must be noted that all future recommendation charts in Rider and Workshop Manuals, and other Service publications will indicate H.D.40 Monograde oils (A.P.I. SD or SE service rating) as the prime engine lubricant recommendations.

**Lubricants Recommended**

Efficient lubrication is of vital importance and it is false economy to use cheap grades of oil. When buying oils or grease it is advisable to specify the brand as well as the grade and, as an additional precaution, to buy from sealed containers.

UNIT	ENGINE	PRIMARY CHAINCASE	GEARBOX	SWINGING ARM BUSHES	HUBS AND FRAME PARTS	FRONT FORKS	REAR CHAIN	EASING RUSTED PARTS
Castrol	Castrol HD40 or Castrol GTX	Castrol GTX	Castrol Hypoy	Castrol Hi-Press	Castrol LM Grease	Castrolite 10W/30	Castrol Graphited Grease	Castrol Penetrating Oil
Mobil	Mobil 40 or Mobil Super 20W/50	Mobil Super or Mobil 20W/50	Mobilube HD90	Mobilube HD140 or C140	Mobilgrease MP or Mobilgrease Super	Mobil Super	Mobilgrease MP or Mobilgrease Super	Mobil Spring Oil or Mobil Handy Oil
Esso	Uniflo or Esso Extra Motor Oil 20W/50	Esso Uniflo	Esso Gear Oil GX90/140	Esso Gear Oil GX90/140	Esso Multipurpose Grease H	Esso Uniflo	Esso MP Grease Moly	Esso Penetrating Oil
Texaco	Marlene SAE40 or Marlene 20W/50	Marlene Motor Oil 20W/50	Multigear Lubricant EP80	Multigear Lubricant EP140	Marlek All-Purpose Grease	Marling Motor Oil 10W/30	Marlek All-Purpose Grease	Graphited Penetrating Oil
Duckhams	Fleet HDX40 or Duckhams Q20/50	Duckhams Q20/50	Duckhams Hypoid 90	Duckhams Hypoid 140	Duckhams LB10 Grease	Duckhams Q3500	Duckhams "Changard"	Duckhams Adrenal Penetrating Oil
Sun Oil	Sun 2000 C SAE40 or Sunoco Special Motor Oil	Sunoco Special Motor Oil	Sunep 1070	Sunep	Sunep 1130	Sunoco Special Motor Oil 20W/50	Sunoco MD2 Moly	Sunoco Penetrating Oil
Filtrate	Filtrate Racing 40 or Filtrate Super 20W/50	Filtrate Super 20W/50	Filtrate EP9C	Filtrate Gear 140	Filtrate Super Lithium Grease	Filtrate AT Fluid F	Filtrate Linklife	Filtrate PDQ
Gulf	Gulf Formula G40 or Gulf Multi-G 20W/50	Gulf Multi-G 20W/50	Gulf Multi-Purpose Gear Lubricant 90	Gulf Multi-Purpose Gear Lubricant 140	Gulfcream Grease No. 2 or Gulfex A	Gulf Multi-G 10W/30	Gulfex Moly	Gulf Penetrating Oil
BP	BP Super Visco-Static 20W/50	BP Super Visco-Static 20W/50	BP Gear Oil SAE 90 EP	BP Gear Oil SAE 90 EP	BP Energrease L2	BP Super Visco-Static 10W/40	BP Energrease AO	BP Penetrating Oil
Shell	Shell Super Motor Oil	Shell Super Motor Oil	Shell Spirax 90 EP	Shell Spirax 90 EP	Shell Retinax A or CD	Shell Super Motor Oil	Shell Retinax A or CD	Shell Easing Oil

## SERVICE RELEASE

N3/60

CATEGORY OF RELEASE: 3

NATURE OF RELEASE: Front brake caliper incorporating stainless steel disc scraper

MODELS AFFECTED: All front disc brake Commando models

DISTRIBUTION: Worldwide (General Distribution)

EXPLANATION: The existing front brake caliper 061927 (serviced as an assembly under part number 061926) has been modified by the addition of two 2.55mm diameter holes on the rear face, to allow the incorporation of a fully floating/self-aligning disc scraper part number 065143.

The scraper is designed to prevent dust and abrasive particles entering the caliper yoke and initiating abrasive wear of the disc and friction lining pads.

ACTION: The new part numbers involved are as under:-

065173 Caliper assembly incorporating disc scraper

065143 Stainless steel disc scraper

NM25100 Screws (self-tapping)

Conversion of existing calipers should be strictly in accordance with the sketch. DO NOT under any circumstances drill the 2.55mm diameter holes deeper than shown, otherwise the fully floating facility will be completely lost. Additionally DO NOT overtighten the self-tap fixing screws for the same reason.

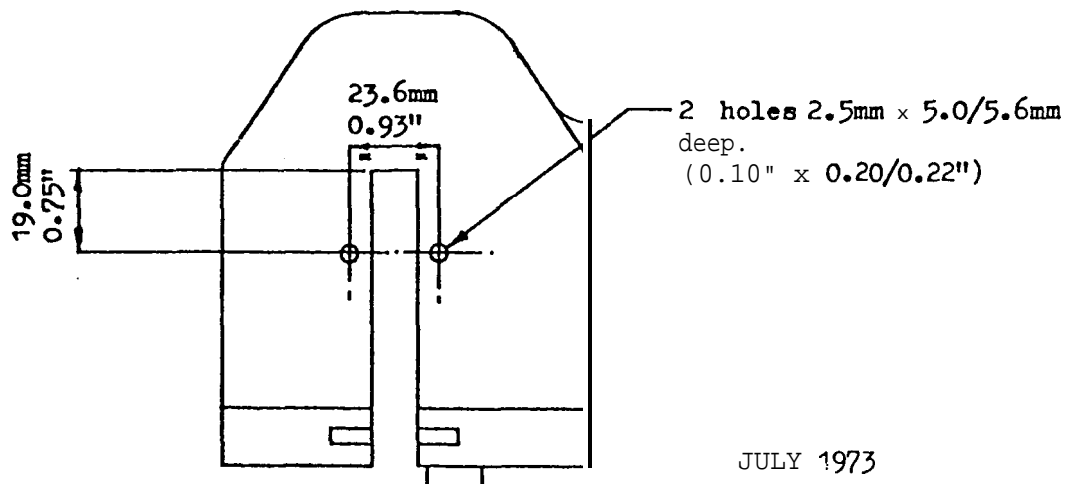

JULY 1973



SERVICE RELEASE

N3/61

CATEGORY OF RELEASE:

3

NATURE OF RELEASE:

Rear wheel bearing spacer

MODELS AFFECTED:

All Commando up to engine number 30

DISTRIBUTION:

Worldwide (General Distribution)

EXPLANATION:

The rear wheel bearing spacer, part number **062070** (item **23** - rear wheel illustration 1972 & 1973 Replacement Parts Lists) has been superseded by a new bearing spacer, in improved material, and is supplied under part number **065290**. The new part is fully interchangeable with the old.

The new bearing spacer overcomes impression from the bearing inner spool, obviating any tendency for the rear wheel spindle to slacken off in service.

ACTION:

All replacement requests for **062070** should now be fulfilled using the new bearing spacer part number **065290**.

JULY 1973



SERVICE RELEASE

N3/63

CATEGORY OF RELEASE:

5

NATURE OF RELEASE:

"Spin-on" Oil Filter Element 063371

MODELS AFFECTED:

750 and 850 models subsequent to engine number 208754

DISTRIBUTION:

Worldwide (General Distribution)

EXPLANATION:

Initial supplies of "spin-on" oil filter elements for both production and replacement spare part supply were manufactured by Messrs. A.C. Deloo.

Additional quantities are now being received, manufactured by Crossland & Wico-Pacy filters, and will be supplied through normal spares channels under the original part number at the existing retail price.

Although the Crossland element is fabricated from a deeper section pressing; both elements are fully interchangeable.

SEPTEMBER 1973





## SERVICE RELEASE

N3/65

CATEGORY OF RELEASE: 4

NATURE OF RELEASE: Warranty Labour Allowance - 850 Model

MODELS AFFECTED: 1973 850 Model Commando only

DISTRIBUTION: Worldwide (General Distribution)

EXPLANATION: The introduction of the 850 model affects the Warranty Labour Allowance schedules as detailed in the Norton Dealer Warranty Manual (claim procedure - 1972 - publication reference NV1229) in respect of the cylinder section (Section 3).

ACTION: Please amend your copy to comply with the revised Factory allowance as detailed below:-

<u>3. CYLINDER</u>	<u>750 MODEL</u>	<u>850 MODEL</u>
Remove and replace cylinder with head attached	1.30	
Remove and replace cylinder barrel		3.30
Fit new cam followers	1.45	3.45
Fit new push rods	1.45	3.00*
Replace piston rings	2.00	4.00
Replace pistons	2.15	4.15

\* Note: Remove and replace push rods now groups with Section 2 for 850 models.

AUGUST 1973



---

SERVICE RELEASE

SERVICE RELEASE

**N3/66**

CATEGORY OF RELEASE:

4

NATURE OF RELEASE:

Luggage carrying and pannier equipment

MODELS AFFECTED:

All Commando (**750** and **850** models)

DISTRIBUTION:

Worldwide (General Distribution)

EXPLANATION:

Customer experience with the many brands of luggage carrying and pannier equipment available to him, indicates that, on safety grounds, we cannot automatically approve the indiscriminate fitment and loading of such equipment to our machines.

We are currently approaching as many such manufacturers as practicable to supply us with equipment to test and set loading limits for use with Commandos.

ACTION:

In the meantime, where customers insist on fitting luggage carrying/pannier equipment, the steering damper must be installed.

A copy of N.V. publication **064629** is attached herewith detailing steering damper kit part number **064247** and providing the necessary fitting instructions.

Further information will be issued in due course.

August, 1973.



SERVICE RELEASE

3/67

**Category of Release :** 5

**Nature of Release:** Norton Villiers - Loctite Machinery Adhesive and Loctite Plastic Gasket

**Models Affected :** Commando (All models)

**Distribution :** Worldwide (general distribution)

**Explanation :** With the increasing use of modern types of adhesives and sealants in current factory production and assembly techniques, individual packs for Dealer and Customer use have now been designed for availability and distribution through Norton spares channels.

- Action :**
1. Use Norton Villiers-Loctite Plastic Gasket for crankcase and cylinder base joints, and for sealing any' joint faces where oil tightness has previously proven to be a problem.
  2. Norton Villiers-Loctite Machinery Adhesive should be used where two mating parts need to be locked together, i.e. nuts, bolts, studs and screws and splines. Specifically designed for retaining bearings on shafts and in housings, it can be used for 'metal to metal applications where the gap does not exceed 0.005in. (0.13mm).

Bubble packs including 10 c .c. bottles are available on display cards, complete with Locquic 'T' Primer Aerosol full instructions in the use of each of these' materials are printed on each card.

**064208 Norton Villiers-Loctite Plastic Gasket**

**064209 Norton Villiers-Loctite Machinery Adhesive**

AUGUST 1973

NORTON VILLIERS CANADA LIMITED



motorcycles

## SERVICE RELEASE

N3/68

CATEGORY OF RELEASE: 4

NATURE OF RELEASE: Cylinder Head Gasket & Gasket Sealant Compound

MODELS AFFECTED: 750 Commando

DISTRIBUTION: Worldwide (General Distribution)

EXPLANATION: Service Release N3/21 introduced 3-750 model cylinder head gaskets:

063844 "Eyeletted" material gasket (0.030in. thick)  
 064071 Copper gasket (0.040in. thick)  
 064072 Alloy gasket (0.080in. thick)

Subsequent service experience prompts the following additional recommendations:-

ACTION:

1. fit the "eyeletted" material cylinder head gasket Part Number 063844 whenever possible, and is permissible on all machines previously using alloy or copper gaskets - provided Premium fuels (minimum 97 octane) are used.
2. Fit the copper gasket 064071 whenever a reduction in compression ratio is required. Always degrease cylinder, gasket and cylinder head faces prior to assembly.

Apply Plastic Gasket ensuring both cylinder bores, oil drain holes and push rod tunnels are continuously circled with Loctite Plastic Gasket on the cylinder face, and after assembly of the copper gasket, similarly applied to the gasket top face.

3. Discontinue use of the alloy gasket. Where fuel availability is below 94 octane, the alloy gasket (or two copper gaskets) may be used provided:-
  - a) Loctite Plastic Gasket compound is used as (2) above.
  - b) Recommended cylinder head torque settings are increased to 35 ft.lbs. ( $\frac{3}{8}$ in. bolts)  
 25 ft.lbs. ( $\frac{5}{16}$ in. bolts etc.)

SEPTEMBER 1973

NORTON VILLIERS CANADA LIMITED